

SHS

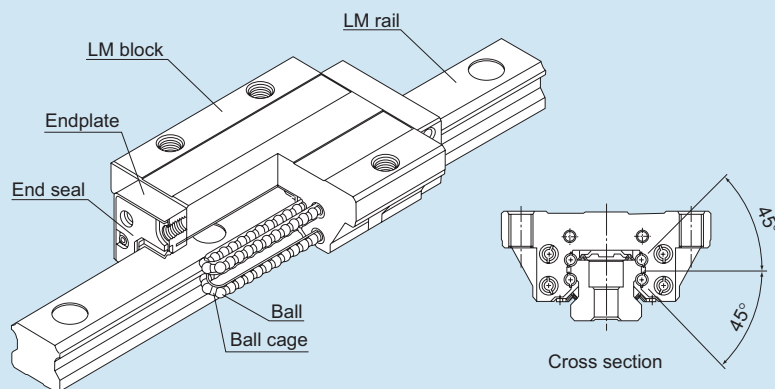

Caged Ball LM Guide Global Standard Size Model SHS



* For the ball cage, see A-130.

Structure and Features	▶▶▶ A-137
Types and Features	▶▶▶ A-138
Rated Loads in All Directions	▶▶▶ A-140
Equivalent Load	▶▶▶ A-140
Service Life	▶▶▶ A-100
Radial Clearance Standard	▶▶▶ A-113
Accuracy Standards	▶▶▶ A-119
Shoulder Height of the Mounting Base and the Corner Radius	▶▶▶ A-327
Error Allowance in the Parallelism between Two Rails	▶▶▶ A-333
Error Allowance in Vertical Level between Two Rails	▶▶▶ A-336
Dimensional Drawing, Dimensional Table, Example of Model Number Coding	▶▶▶ B-6
Standard Length and Maximum Length of the LM Rail	▶▶▶ B-12
Tapped-hole LM Rail Type of Model SHS	▶▶▶ B-13

Structure and Features

Balls roll in four rows of raceways precision-ground on an LM rail and an LM block, and ball cages and endplates incorporated in the LM block allow the balls to circulate.

Each row of balls is placed at a contact angle of 45° so that the rated loads applied to the LM block are uniform in the four directions (radial, reverse radial and lateral directions), enabling the LM Guide to be used in all orientations. In addition, the LM block can receive a well-balanced preload, increasing the rigidity in the four directions while maintaining a constant, low friction coefficient. With the low sectional height and the high rigidity design of the LM block, this model achieves highly accurate and stable straight motion.

[4-way Equal Load]

Each row of balls is placed at a contact angle of 45° so that the rated loads applied to the LM block are uniform in the four directions (radial, reverse radial and lateral directions), enabling the LM Guide to be used in all orientations and in extensive applications.

[Self-adjustment Capability]

The self-adjustment capability through front-to-front configuration of THK's unique circular-arc grooves (DF set) enables a mounting error to be absorbed even under a preload, thus to achieve highly accurate, smooth straight motion.

[Global Standard Size]

SHS is designed to have dimensions almost the same as that of Full Ball LM Guide model HSR, which THK as a pioneer of the linear motion system has developed and is practically a global standard size.

[Low Center of Gravity, High Rigidity]

As a result of downsizing the LM rail section, the center of gravity is lowered and the rigidity is increased.

Types and Features

Model SHS-C

The flange of the LM block has tapped holes.
Can be mounted from the top or the bottom.
Used in places where the table cannot have through holes for mounting bolts.

Specification Table⇒B-6

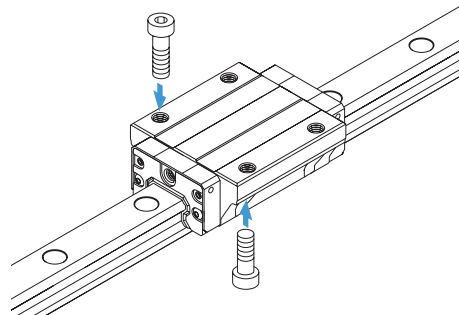

Model SHS-V

With this type, the LM block has a smaller width (W) and tapped holes.
Used in places where the space for table width is limited.

Specification Table⇒B-8

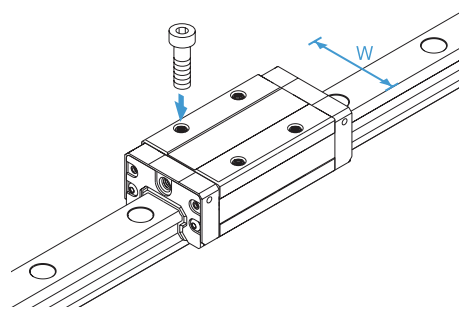

Model SHS-R

The LM block has a smaller width (W) and the mounting holes are tapped.
It succeeds the height dimension of full-ball type LM Guide HSR-R.

Specification Table⇒B-10

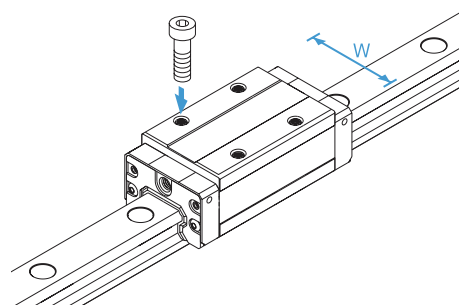

Features of Each Model
Global Standard Size Model SHS

Model SHS-LC

The LM block has the same cross-sectional shape as model SHS-C, but has a longer overall LM block length (L) and a greater rated load.

Specification Table⇒B-6

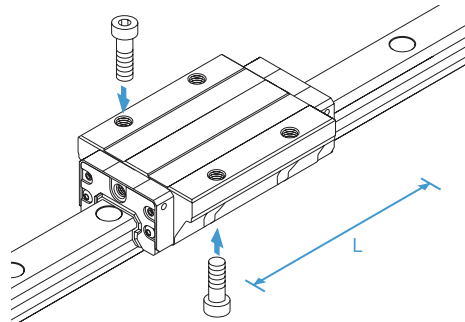

LM Guide

Model SHS-LV

The LM block has the same cross-sectional shape as model SHS-V, but has a longer overall LM block length (L) and a greater rated load.

Specification Table⇒B-8

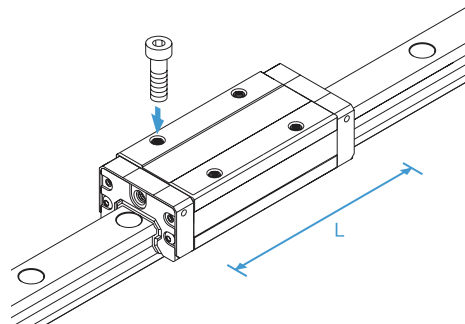

Model SHS-LR

The LM block has the same cross-sectional shape as model SHS-R, but has a longer overall LM block length (L) and a greater rated load.

Specification Table⇒B-10

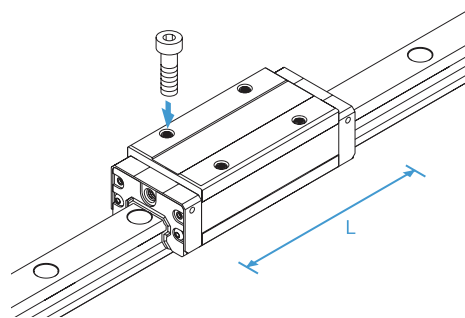

Rated Loads in All Directions

Model SHS is capable of receiving loads in four directions: radial, reverse radial and lateral directions.

The basic load ratings are uniform in the four directions (radial, reverse radial and lateral directions), and their actual values are provided in the specification table for SHS.

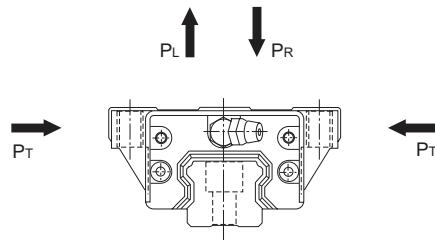

Fig.1

Equivalent Load

When the LM block of model SHS receives loads in all directions simultaneously, the equivalent load is obtained from the equation below.

$$P_E = P_R (P_L) + P_T$$

P_E	: Equivalent load	(N)
	: Radial direction	
	: Reverse radial direction	
	: Lateral direction	
P_R	: Radial load	(N)
P_L	: Reverse radial load	(N)
P_T	: Lateral load	(N)

Service Life

For details, see A-100.

Radial Clearance Standard

For details, see A-113.

Accuracy Standards

For details, see A-119.

Shoulder Height of the Mounting Base and the Corner Radius

For details, see A-327.

Error Allowance in the Parallelism between Two Rails

For details, see A-333.

Error Allowance in Vertical Level between Two Rails

For details, see A-336.



Models SHS-C and SHS-LC

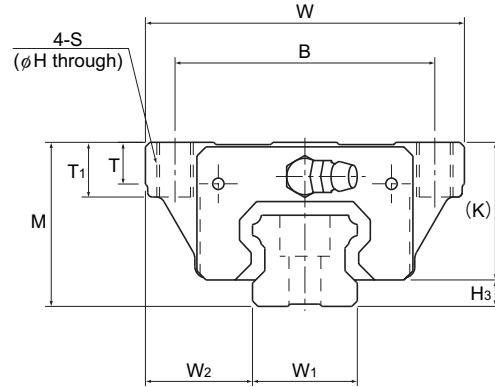

Model No.	Outer dimensions			LM block dimensions													Pilot hole for side nipple**		
	Height	Width	Length	B	C	S	H	L ₁	T	T ₁	K	N	E	Grease nipple	e ₀	f ₀	D ₀		
	M	W	L																
SHS 15C SHS 15LC	24	47	64.4 79.4	38	30	M5	4.4	48 63	5.9	8	21	5.5	5.5	PB1021B	4	4	3		
SHS 20C SHS 20LC	30	63	79 98	53	40	M6	5.4	59 78	7.2	10	25.4	6.5	12	B-M6F	4.3	5.3	3		
SHS 25C SHS 25LC	36	70	92 109	57	45	M8	6.8	71 88	9.1	12	30.2	7.5	12	B-M6F	6	5.5	3		
SHS 30C SHS 30LC	42	90	106 131	72	52	M10	8.5	80 105	11.5	15	35	8	12	B-M6F	5.5	6	5.2		
SHS 35C SHS 35LC	48	100	122 152	82	62	M10	8.5	93 123	11.5	15	40.5	8	12	B-M6F	6.5	5.5	5.2		
SHS 45C SHS 45LC	60	120	140 174	100	80	M12	10.5	106 140	14.1	18	51.1	10.5	16	B-PT1/8	8	8	5.2		
SHS 55C SHS 55LC	70	140	171 213	116	95	M14	12.5	131 173	16	21	57.3	11	16	B-PT1/8	10	8	5.2		
SHS 65C SHS 65LC	90	170	221 272	142	110	M16	14.5	175 226	18.8	24	71	19	16	B-PT1/8	10	12	5.2		

Model number coding

SHS25 LC 2 QZ KKH C0 +1200L P T Z - II

Model number

Type of LM block

With QZ Lubricator

Contamination protection accessory symbol (*1)

LM rail length (in mm)

With steel tape

Symbol for No. of rails used on the same plane (*4)

No. of LM blocks used on the same rail

Radial clearance symbol (*2)
Normal (No symbol)
Light preload (C1)
Medium preload (C0)

Accuracy symbol (*3)
Normal grade (No Symbol)/High accuracy grade (H)
Precision grade (P)/Super precision grade (SP)
Ultra precision grade (UP)

Symbol for LM rail jointed use

(*1) See contamination protection accessory on A-368. (*2) See A-113. (*3) See A-119. (*4) See A-59.

Note) This model number indicates that a single-rail unit constitutes one set. (i.e., required number of sets when 2 rails are used in parallel is 2 at a minimum.)

Those models equipped with QZ Lubricator cannot have a grease nipple.

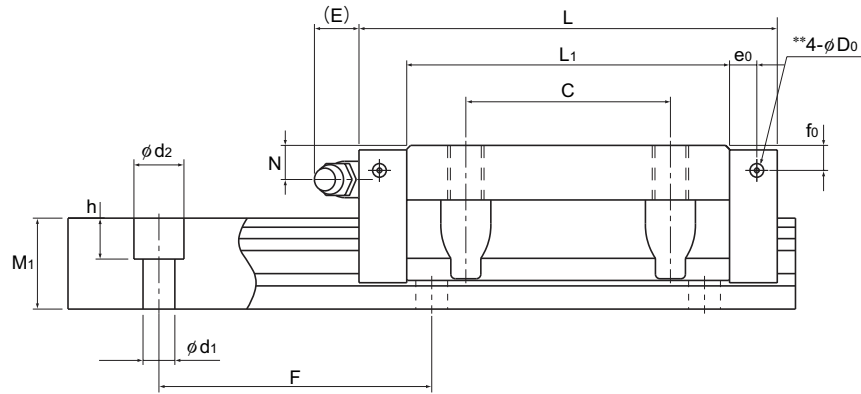

LM Guide

Unit: mm

H ₃	LM rail dimensions						Basic load rating		Static permissible moment kN-m*					Mass	
	Width	Height	Pitch	d ₁ × d ₂ × h	Length*	C	C ₀	M _A		M _B		M _C	LM block	LM rail	
	W ₁ 0 -0.05	W ₂	M ₁					F	1 block	Double blocks	1 block	Double blocks	1 block	kg	kg/m
3	15	16	13	60	4.5 × 7.5 × 5.3	2500	14.2 17.2	24.2 31.9	0.175 0.296	0.898 1.43	0.175 0.296	0.898 1.43	0.16 0.212	0.23 0.29	1.3
4.6	20	21.5	16.5	60	6 × 9.5 × 8.5	3000	22.3 28.1	38.4 50.3	0.334 0.568	1.75 2.8	0.334 0.568	1.75 2.8	0.361 0.473	0.46 0.61	2.3
5.8	23	23.5	20	60	7 × 11 × 9	3000	31.7 36.8	52.4 64.7	0.566 0.848	2.75 3.98	0.566 0.848	2.75 3.98	0.563 0.696	0.72 0.89	3.2
7	28	31	23	80	9 × 14 × 12	3000	44.8 54.2	66.6 88.8	0.786 1.36	4.08 6.6	0.786 1.36	4.08 6.6	0.865 1.15	1.34 1.66	4.5
7.5	34	33	26	80	9 × 14 × 12	3000	62.3 72.9	96.6 127	1.36 2.34	6.76 10.9	1.38 2.34	6.76 10.9	1.53 2.01	1.9 2.54	6.2
8.9	45	37.5	32	105	14 × 20 × 17	3090	82.8 100	126 166	2.05 3.46	10.1 16.3	2.05 3.46	10.1 16.3	2.68 3.53	3.24 4.19	10.4
12.7	53	43.5	38	120	16 × 23 × 20	3060	128 161	197 259	3.96 6.68	19.3 31.1	3.96 6.68	19.3 31.1	4.9 6.44	5.35 6.97	14.5
19	63	53.5	53	150	18 × 26 × 22	3000	205 253	320 408	8.26 13.3	40.4 62.6	8.26 13.3	40.4 62.6	9.4 11.9	10.7 13.7	23.7

Note) Pilot holes for side nipples** are not drilled through in order to prevent foreign material from entering the product. THK will mount grease nipples per your request. Therefore, do not use the side nipple pilot holes** for purposes other than mounting a grease nipple.
 The maximum length under "Length*" indicates the standard maximum length of an LM rail. (See B-12.)
 Static permissible moment*: 1 block: static permissible moment value with 1 LM block
 Double blocks: static permissible moment value with 2 blocks closely contacting with each other

Models SHS-V and SHS-LV

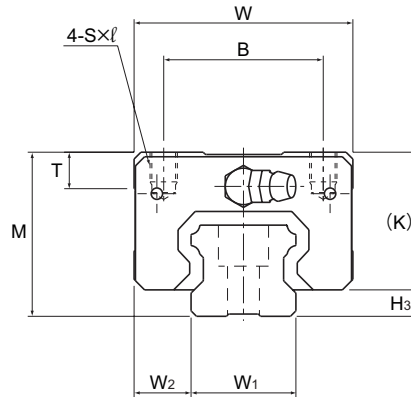

Model No.	Outer dimensions			LM block dimensions										Pilot hole for side nipple**		
	Height	Width	Length	B	C	S×ℓ	L ₁	T	K	N	E	Grease nipple	e ₀	f ₀	D ₀	
	M	W	L													
SHS 15V SHS 15LV	24	34	64.4 79.4	26	26 34	M4×4	48 63	5.9	21	5.5	5.5	PB1021B	4	4	3	
SHS 20V SHS 20LV	30	44	79 98	32	36 50	M5×5	59 78	8	25.4	6.5	12	B-M6F	4.3	5.3	3	
SHS 25V SHS 25LV	36	48	92 109	35	35 50	M6×6.5	71 88	8	30.2	7.5	12	B-M6F	6	5.5	3	
SHS 30V SHS 30LV	42	60	106 131	40	40 60	M8×8	80 105	8	35	8	12	B-M6F	5.5	6	5.2	
SHS 35V SHS 35LV	48	70	122 152	50	50 72	M8×10	93 123	14.7	40.5	8	12	B-M6F	6.5	5.5	5.2	
SHS 45V SHS 45LV	60	86	140 174	60	60 80	M10×15	106 140	14.9	51.1	10.5	16	B-PT1/8	8	8	5.2	
SHS 55V SHS 55LV	70	100	171 213	75	75 95	M12×15	131 173	19.4	57.3	11	16	B-PT1/8	10	8	5.2	
SHS 65V SHS 65LV	90	126	221 272	76	70 120	M16×20	175 226	19.5	71	19	16	B-PT1/8	10	12	5.2	

Model number coding

SHS30	V	2	QZ	KKHH	C1	+1240L	P	T	Z	-II
Model number	Type of LM block	No. of LM blocks used on the same rail	With QZ Lubricator	Contamination protection accessory symbol (*1)	Radial clearance symbol (*2)	LM rail length (in mm)		With steel tape	Symbol for LM rail jointed use	Symbol for No. of rails used on the same plane (*4)
					Normal (No symbol) Light preload (C1) Medium preload (C0)				Accuracy symbol (*3) Normal grade (No Symbol)/High accuracy grade (H) Precision grade (P)/Super precision grade (SP) Ultra precision grade (UP)	

(*1) See contamination protection accessory on A-368. (*2) See A-113. (*3) See A-119. (*4) See A-59.

Note) This model number indicates that a single-rail unit constitutes one set. (i.e., required number of sets when 2 rails are used in parallel is 2 at a minimum.)

Those models equipped with QZ Lubricator cannot have a grease nipple.

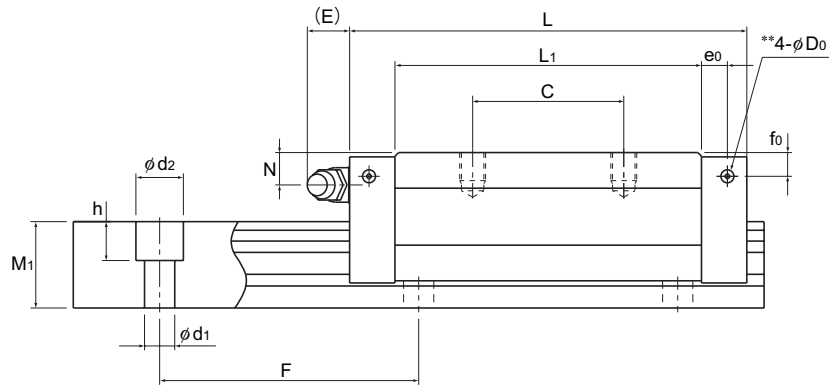

LM Guide

Unit: mm

	LM rail dimensions							Basic load rating		Static permissible moment kN-m*					Mass	
	H ₃	Width	Height	Pitch	d ₁ × d ₂ × h	Length* Max	C kN	C ₀ kN	M _A		M _B		M _C	LM block kg	LM rail kg/m	
		W ₁ 0 -0.05							W ₂	M ₁	F	1 block				Double blocks
3	15	9.5	13	60	4.5 × 7.5 × 5.3	2500	14.2 17.2	24.2 31.9	0.175 0.296	0.898 1.43	0.175 0.296	0.898 1.43	0.16 0.212	0.19 0.22	1.3	
4.6	20	12	16.5	60	6 × 9.5 × 8.5	3000	22.3 28.1	38.4 50.3	0.334 0.568	1.75 2.8	0.334 0.568	1.75 2.8	0.361 0.473	0.35 0.46	2.3	
5.8	23	12.5	20	60	7 × 11 × 9	3000	31.7 36.8	52.4 64.7	0.566 0.848	2.75 3.98	0.566 0.848	2.75 3.98	0.563 0.696	0.54 0.67	3.2	
7	28	16	23	80	9 × 14 × 12	3000	44.8 54.2	66.6 88.8	0.786 1.36	4.08 6.6	0.786 1.36	4.08 6.6	0.865 1.15	0.94 1.16	4.5	
7.5	34	18	26	80	9 × 14 × 12	3000	62.3 72.9	96.6 127	1.38 2.34	6.76 10.9	1.38 2.34	6.76 10.9	1.53 2.01	1.4 1.84	6.2	
8.9	45	20.5	32	105	14 × 20 × 17	3090	82.8 100	126 166	2.05 3.46	10.1 16.3	2.05 3.46	10.1 16.3	2.68 3.53	2.54 3.19	10.4	
12.7	53	23.5	38	120	16 × 23 × 20	3060	128 161	197 259	3.96 6.68	19.3 31.1	3.96 6.68	19.3 31.1	4.9 6.44	4.05 5.23	14.5	
19	63	31.5	53	150	18 × 26 × 22	3000	205 253	320 408	8.26 13.3	40.4 62.6	8.26 13.3	40.4 62.6	9.4 11.9	8.41 10.7	23.7	

Note) Pilot holes for side nipples** are not drilled through in order to prevent foreign material from entering the product.
 THK will mount grease nipples per your request. Therefore, do not use the side nipple pilot holes** for purposes other than mounting a grease nipple.
 The maximum length under "Length*" indicates the standard maximum length of an LM rail. (See B-12.)
 Static permissible moment*: 1 block: static permissible moment value with 1 LM block
 Double blocks: static permissible moment value with 2 blocks closely contacting with each other

Models SHS-R and SHS-LR

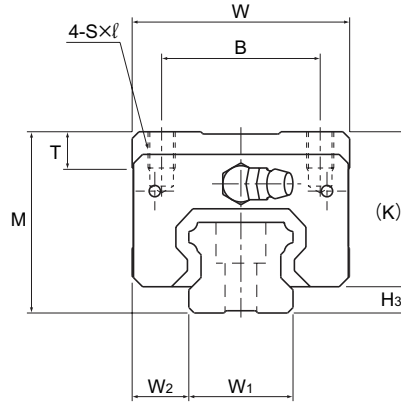

Model No.	Outer dimensions			LM block dimensions										Pilot hole for side nipple**		
	Height	Width	Length	B	C	S×ℓ	L ₁	T	K	N	E	Grease nipple	e ₀	f ₀	D ₀	
	M	W	L													
SHS 15R	28	34	64.4	26	26	M4×5	48	5.9	25	9.5	5.5	PB1021B	4	8	3	
SHS 25R SHS 25LR	40	48	92 109	35	35 50	M6×8	71 88	8	34.2	11.5	12	B-M6F	6	9.5	3	
SHS 30R SHS 30LR	45	60	106 131	40	40 60	M8×10	80 105	8	38	11	12	B-M6F	5.5	9	5.2	
SHS 35R SHS 35LR	55	70	122 152	50	50 72	M8×12	93 123	14.7	47.5	15	12	B-M6F	6.5	12.5	5.2	
SHS 45R SHS 45LR	70	86	140 174	60	60 80	M10×17	106 140	14.9	61.1	20.5	16	B-PT1/8	8	18	5.2	
SHS 55R SHS 55LR	80	100	171 213	75	75 95	M12×18	131 173	19.4	67.3	21	16	B-PT1/8	10	18	5.2	

Model number coding

SHS45 LR 2 QZ KKHH C0 +1200L P T -II

Model number

Type of LM block

With QZ Lubricator

Contamination protection accessory symbol (*1)

LM rail length (in mm)

Symbol for LM rail jointed use

Symbol for No. of rails used on the same plane (*4)

No. of LM blocks used on the same rail

Radial clearance symbol (*2)
Normal (No symbol)
Light preload (C1)
Medium preload (C0)

Accuracy symbol (*3)
Normal grade (No Symbol)/High accuracy grade (H)
Precision grade (P)/Super precision grade (SP)
Ultra precision grade (UP)

(*1) See contamination protection accessory on A-368. (*2) See A-113. (*3) See A-119. (*4) See A-59.

Note) This model number indicates that a single-rail unit constitutes one set. (i.e., required number of sets when 2 rails are used in parallel is 2 at a minimum.)

Those models equipped with QZ Lubricator cannot have a grease nipple.

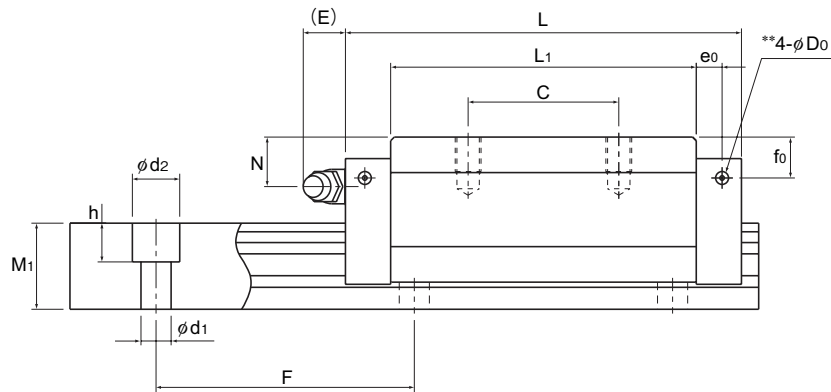

LM Guide

Unit: mm

H ₃	LM rail dimensions						Basic load rating		Static permissible moment kN-m*					Mass	
	Width	Height	Pitch	d ₁ × d ₂ × h	Length h*	C	C ₀	M _A		M _B		M _C	LM block	LM rail	
	W ₁	W ₂	M ₁					F	1 block	Double blocks	1 block	Double blocks			1 block
3	15	9.5	13	60	4.5 × 7.5 × 5.3	2500	14.2	24.2	0.175	0.898	0.175	0.898	0.16	0.22	1.3
5.8	23	12.5	20	60	7 × 11 × 9	3000	31.7 36.8	52.4 64.7	0.556 0.848	2.75 3.98	0.566 0.848	2.75 3.98	0.563 0.696	0.66 0.8	3.2
7	28	16	23	80	9 × 14 × 12	3000	44.8 54.2	66.6 88.8	0.786 1.36	4.08 6.6	0.786 1.36	4.08 6.6	0.865 1.15	1.04 1.36	4.5
7.5	34	18	26	80	9 × 14 × 12	3000	62.3 72.9	96.6 127	1.38 2.34	6.76 10.9	1.38 2.34	6.76 10.9	1.53 2.01	1.8 2.34	6.2
8.9	45	20.5	32	105	14 × 20 × 17	3090	82.8 100	126 166	2.05 3.46	10.1 16.3	2.05 3.46	10.1 16.3	2.68 3.53	3.24 4.19	10.4
12.7	53	23.5	38	120	16 × 23 × 20	3060	128 161	197 259	3.96 6.68	19.3 31.1	3.96 6.68	19.3 31.1	4.9 6.44	5.05 6.57	14.5

Note) Pilot holes for side nipples** are not drilled through in order to prevent foreign material from entering the product.
 THK will mount grease nipples per your request. Therefore, do not use the side nipple pilot holes** for purposes other than mounting a grease nipple.
 The maximum length under "Length*" indicates the standard maximum length of an LM rail. (See B-12.)
 Static permissible moment*: 1 block: static permissible moment value with 1 LM block
 Double blocks: static permissible moment value with 2 blocks closely contacting with each other

Standard Length and Maximum Length of the LM Rail

Table1 shows the standard lengths and the maximum lengths of model SHS variations. If the maximum length of the desired LM rail exceeds them, jointed rails will be used. Contact THK for details. For the G dimension when a special length is required, we recommend selecting the corresponding G value from the table. The longer the G dimension is, the less stable the G area may become after installation, thus causing an adverse impact to accuracy.

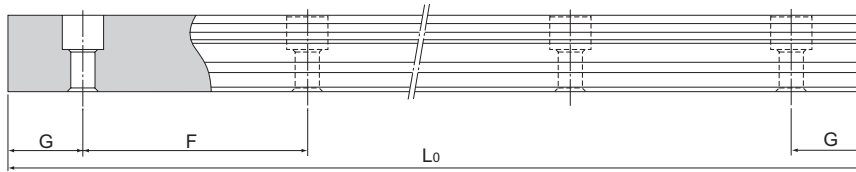

Table1 Standard Length and Maximum Length of the LM Rail for Model SHS

Unit: mm

Model No.	SHS 15	SHS 20	SHS 25	SHS 30	SHS 35	SHS 45	SHS 55	SHS 65
LM rail standard length (L ₀)	160	220	220	280	280	570	780	1270
	220	280	280	360	360	675	900	1570
	280	340	340	440	440	780	1020	2020
	340	400	400	520	520	885	1140	2620
	400	460	460	600	600	990	1260	
	460	520	520	680	680	1095	1380	
	520	580	580	760	760	1200	1500	
	580	640	640	840	840	1305	1620	
	640	700	700	920	920	1410	1740	
	700	760	760	1000	1000	1515	1860	
	760	820	820	1080	1080	1620	1980	
	820	940	940	1160	1160	1725	2100	
	940	1000	1000	1240	1240	1830	2220	
	1000	1060	1060	1320	1320	1935	2340	
	1060	1120	1120	1400	1400	2040	2460	
	1120	1180	1180	1480	1480	2145	2580	
	1180	1240	1240	1560	1560	2250	2700	
	1240	1360	1300	1640	1640	2355	2820	
	1360	1480	1360	1720	1720	2460	2940	
	1480	1600	1420	1800	1800	2565	3060	
	1600	1720	1480	1880	1880	2670		
		1840	1540	1960	1960	2775		
		1960	1600	2040	2040	2880		
		2080	1720	2200	2200	2985		
		2200	1840	2360	2360	3090		
		1960	2520	2520				
		2080	2680	2680				
		2200	2840	2840				
		2320	3000	3000				
		2440						
Standard pitch F	60	60	60	80	80	105	120	150
G	20	20	20	20	20	22.5	30	35
Max length	2500	3000	3000	3000	3000	3090	3060	3000

Note1) The maximum length varies with accuracy grades. Contact THK for details.

Note2) If jointed rails are not allowed and a greater length than the maximum values above is required, contact THK.

Tapped-hole LM Rail Type of Model SHS

The model SHS variations include a type with its LM rail bottom tapped. This type is useful when desiring to mount the LM Guide from the bottom of the base and when desiring to increase the contamination protection effect.

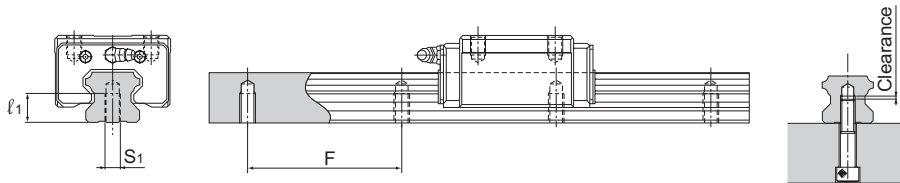

LM Guide

- (1) Determine the bolt length so that a clearance of 2 to 5 mm is secured between the bolt end and the bottom of the tap (effective tap depth). (See figure above.)
- (2) For standard pitches of the taps, see Table1 on B-12.

Table2 Dimensions of the LM Rail Tap

Unit: mm

Model No.	S ₁	Effective tap depth l_1
SHS 15	M5	8
SHS 20	M6	10
SHS 25	M6	12
SHS 30	M8	15
SHS 35	M8	17
SHS 45	M12	24
SHS 55	M14	24
SHS 65	M20	30

Model number coding

SHS35 LC2UU +1000LH K

Symbol for
tapped-hole LM rail type

