

# Track Roller Guidance Systems

Track roller guidance systems  
Track rollers, bolts, guideways  
Accessories

**SCHAEFFLER**



The background of the page is a technical drawing of a track roller guidance system. It shows a cross-section of a track with rollers and a guide shoe. Dimensions are indicated with arrows and labels: '1', '2', '4' at the top; 'B' on the right; 'a2' and 'N3' in the lower left. The drawing uses hatching to indicate different materials or sections.

# Track Roller Guidance Systems

Track roller guidance systems  
Track rollers, bolts, guideways  
Accessories

All data have been prepared with a great deal of care and checked for their accuracy. However, no liability can be assumed for any incorrect or incomplete data. We reserve the right to make technical modifications.

© Schaeffler Technologies AG & Co. KG

Issued: 2016, June

Reproduction in whole or in part without our authorisation is prohibited.

# Foreword

Track roller guidance systems LF are highly suitable, due to their lightweight construction, for applications in handling systems where low-noise running, high speeds and long travel distances are required together with low, uniform displacement resistance.

## **Economical modular concept**

In order to cover a wide range of requirements using standard components, the guidance systems are structured according to a modular concept. The system elements, namely carriages, composite guideways, track rollers and a precisely matched range of accessories can be combined to achieve designs that are precisely matched to the application.

## **Carriages**

Carriages LF are supplied in the form of:

- economical, lightweight hollow section carriages
- robust open carriages for high performance guidance systems of a simple construction
- enclosed, compact carriages where guidance systems must operate in contaminated environments
- non-locating bearing carriages for locating and non-locating bearing applications with two guidance systems in a parallel arrangement
- bogie carriages for curved tracks or closed oval and circular guidance systems.

## **Guideways**

Composite guideways are available as solid and hollow section guideways, with a support rail of high bending rigidity, as a half guideway, a curved guideway element or a flat design. Guideways with slots for toothed racks or toothed belts are also available.

## **Profiled track rollers**

Profiled track rollers without filling slots are used to guide the carriages and support the forces. These double row angular contact ball bearings have an outer ring with a gothic arch profile raceway, are sealed on both sides and are greased for life. They can support axial loads from both sides and high radial forces due to the thick-walled outer ring.

## **Accessories**

The spectrum of positive characteristics of our track roller guidance systems is completed by a comprehensive, precisely matched range of accessories for the system components.



# Contents

	Page
Product index .....	6
Tab index .....	8
Track roller guidance systems	
Technical principles .....	10
Track roller guidance systems .....	40
Track rollers, bolts, guideways .....	66
Accessories .....	104
Addresses .....	124

# Product index

	Page
AB	Lubrication and wiper unit for LFL-SF ..... 117
AB.LFR	Cap wiper for LFCL..... 118
AB.W	Lubrication and wiper unit for guideways..... 116
ABAL	Side plate for LFL-SF..... 119
ANS.LFS	End plate for solid profile guideway..... 115
ANS.LFS..-C	End plate for hollow section guideway..... 115
ANS.LFS..-F	End plate for flat guideway ..... 115
ANS.LFS..-FH	End plate for flat half guideway ..... 115
ANS.LFS..-NZZ	End plate for guideway with slots ..... 115
KA.LFS..-C	End cover for hollow section guideway ..... 122
KA.LFS..-M	End cover for profiled section guideway..... 122
LEIS	T-strip..... 113
LFCL	Hollow section carriage, clearance-free ..... 56
LFDL..-B	Bogie carriage, adjustable clearance ..... 64
LFDL..-SF	Bogie carriage, clearance-free ..... 64
LFE	Eccentric bolt..... 88
LFE..-A1	Eccentric bolt with relubrication hole..... 88
LFKL..-SF	Compact carriage, clearance-free ..... 58
LFKL..-E-SF	Compact carriage, clearance-free, with heavy duty track rollers ..... 58
LFKL..-EE-SF	Compact carriage, clearance-free, with heavy duty track rollers ..... 58
LFL..-SF	Open carriage, clearance-free..... 60
LFL..-E-SF	Open carriage, clearance-free, with heavy duty track rollers ..... 60
LFL..-SF	Non-locating bearing carriage, clearance-free ..... 62
LFR..-2RS-RB	Locating bearing profiled track roller ..... 84
LFR..-2Z	Locating bearing profiled track roller ..... 84
LFRI	Profiled track roller with extended inner ring..... 86
LFR..-2RSR-NA	Non-locating bearing track roller ..... 90
LFR..-2RSR-RNA	Non-locating bearing profiled track roller without inner ring ..... 90



	Page
LFS	Guideway, solid profile ..... 94
LFS..-C	Guideway, hollow section profile ..... 94
LFS..-CE	Guideway, hollow section profile ..... 94
LFS..-CEE	Guideway, hollow section profile ..... 94
LFS..-E	Guideway, solid profile ..... 94
LFS..-EE	Guideway, solid profile ..... 94
LFS..-F	Guideway, flat guideway ..... 94
LFS..-FE	Guideway, flat guideway ..... 94
LFS..-FH	Guideway, flat half guideway ..... 96
LFS..-FHE	Guideway, flat half guideway ..... 96
LFS..-FHEE	Guideway, flat half guideway ..... 96
LFS..-M	Guideway, profiled section guideway ..... 98
LFS..-N	Guideway with slots..... 98
LFS..-NZZ	Guideway with slots..... 98
LFS..-RB	Guideway, corrosion-resistant design ..... 94
LFSR..-ST	Guideway, curved guideway element ..... 100
LFS..-OV../180-VBS	Closed oval track with 180° arcs and guideway connectors..... 102
LFS..-OV../90-VBS	Closed oval track with 90° arcs and guideway connectors..... 102
LFZ	Concentric bolt ..... 88
LFZ..-A1	Concentric bolt with relubrication hole ..... 88
MU	T-nut ..... 113
MU..POS	Positionable T-nut ..... 113
NAD	Slot closing strip for LFS..-M..... 123
PAH	Stop for guideways ..... 121
PASTP	Stop for guideways ..... 120
SHR	T-bolts..... 113
SPPR	Fixing lug..... 113
VBS	Guideway connector for guideways ..... 114

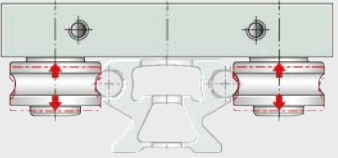
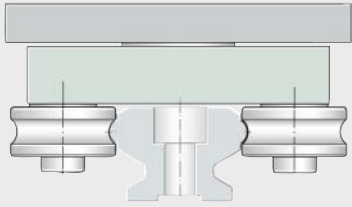
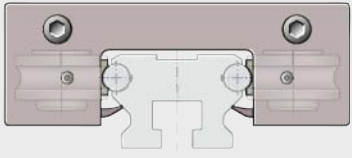
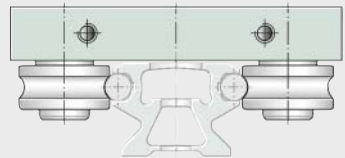

0001AC17

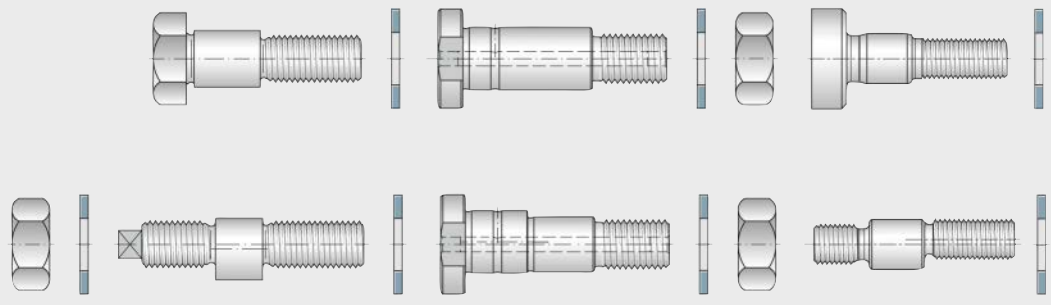

0001AD16

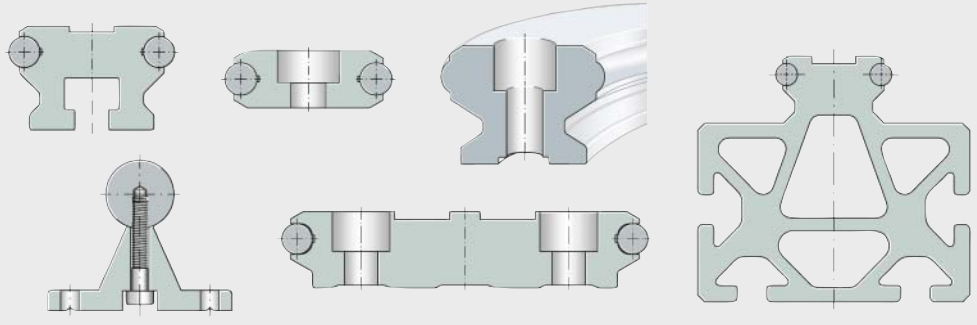

0001A400

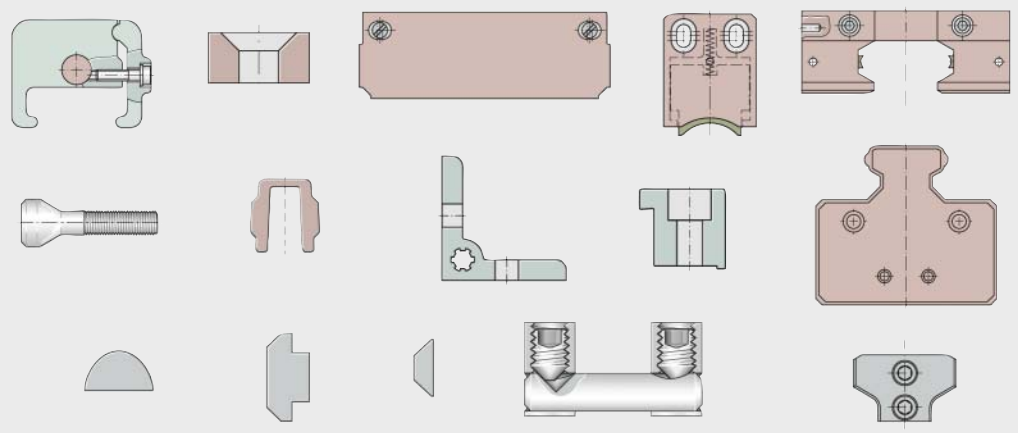

1211673

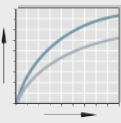

0001A282

## Technical principles

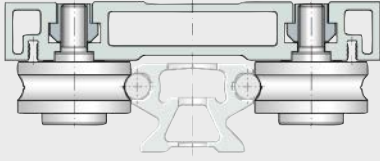

0001AC1B

### Track roller guidance systems

- With hollow section carriage
- With compact carriage
- With open carriage
- With non-locating bearing carriage
- With bogie carriage

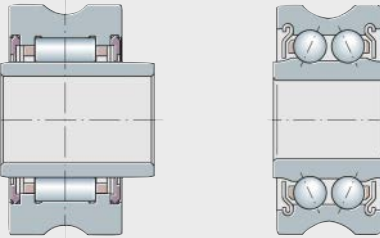

121 670

### Track rollers

- Locating bearing track roller
- Non-locating bearing track roller

### Bolts

- Concentric
- Eccentric

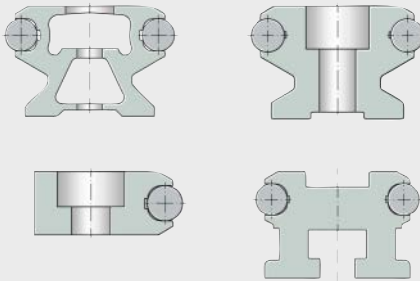

0001A401

### Guideways

- With solid or hollow section profile
- Flat design
- With support rail
- With slots
- Half guideway
- Curved guideway element

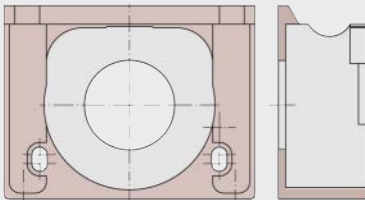

0001A402

### Accessories



0001A281

### Addresses

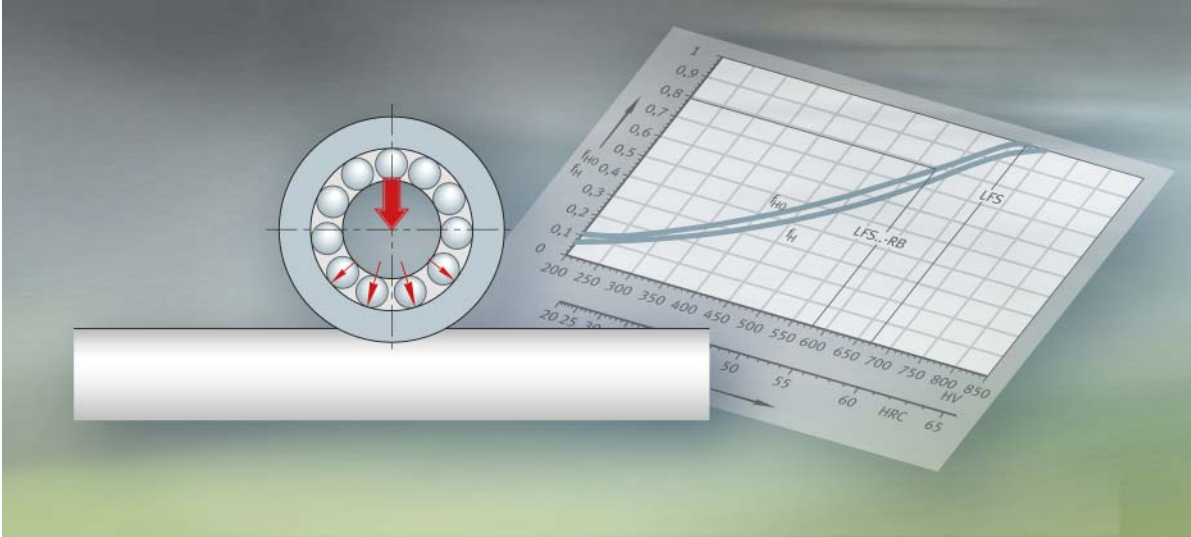

## Technical principles

- Load carrying capacity and rating life
- Lubrication
- Design of bearing arrangements
- Mounting
- Accuracy
- Ordering designations
- Operating limits



# Technical principles

	Page	
<b>Load carrying capacity and rating life</b>	Permissible radial loads .....	12
	Permissible radial load under dynamic loading.....	12
	Permissible radial load under static loading .....	13
	Fatigue limit load .....	13
	Calculation of rating life.....	13
	Rating life of track rollers.....	14
	Operating life.....	16
	Static load safety factor.....	17
	Minimum load.....	18
	Differences in raceway hardness .....	18
<b>Lubrication</b>	Lubrication of guideway raceways.....	19
	Lubrication intervals .....	19
	Lubrication of track rollers.....	19
<b>Design of bearing arrangements</b>	Requirements for the adjacent construction .....	21
	Shaft creep .....	21
	Displacement force .....	21
	Location of carriages and guideways .....	22
	Track roller guidance systems in accordance with customer specifications.....	22
<b>Mounting</b>	Delivered condition .....	26
	Mounting of guidance system with one guideway.....	26
	Mounting of guidance system with two guideways.....	27
	Mounting of curved guideway elements and oval tracks .....	27
	Mounting of bogie carriages.....	27
<b>Accuracy</b>	Accuracy of guideways LFS.....	30
<b>Ordering example, ordering designation</b>	Ready-to-fit systems .....	34
	Closed oval tracks .....	36
	Oval track with two 180° arcs .....	36
	Oval track with four 90° arcs .....	37
	Individual components .....	38
<b>Operating limits</b>	Operating temperature .....	39
	Velocities .....	39
	Acceleration .....	39

# Load carrying capacity and rating life

## Permissible radial loads

The thick-walled outer rings of the track rollers can support high radial loads. If these track rollers are used against a shaft as a raceway, the outer rings undergo elastic deformation, *Figure 1*.

Compared to rolling bearings supported in a housing bore, track rollers have the following characteristics:

- modified load distribution in the bearing. This is taken into consideration by means of the basic load ratings  $C_{rw}$  and  $C_{Orw}$  used in the calculation of the rating life
- bending stress in the outer ring. This is taken into consideration by means of the permissible radial loads  $F_{r\text{per}}$  and  $F_{Or\text{per}}$ . The bending stresses must not exceed the permissible strength values of the material (due to the risk of fracture).

## Permissible radial load under dynamic loading



For rotating bearings under dynamic load, the effective dynamic load rating  $C_{rw}$  is used.  $C_{rw}$  is used to calculate the basic rating life.

The permissible dynamic radial load  $F_{r\text{per}}$  must not be exceeded. If the basic static load rating  $C_{Orw}$  is lower than the basic dynamic load rating  $C_{rw}$ ,  $C_{Orw}$  is used.

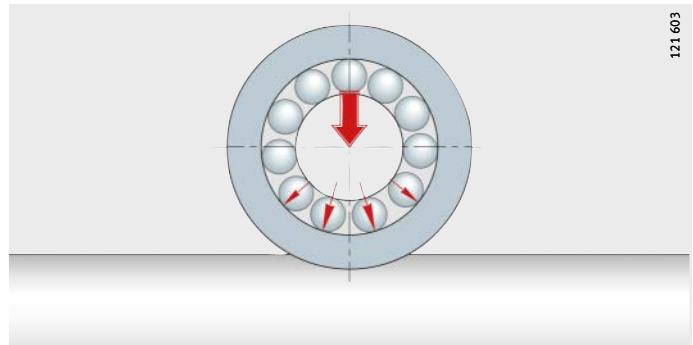

*Figure 1*  
Deformation of the outer ring  
when used against a flat raceway



### Permissible radial load under static loading

For bearings under static load, when stationary or with only infrequent motion, the effective static load rating  $C_{0rW}$  is used.  $C_{0rW}$  is used to calculate the static load safety factor  $S_0$ .



At the same time, the permissible static radial load  $F_{0r\text{per}}$  must not be exceeded.

In addition to the permissible radial load of the bearing, the permissible radial load of the mating track must also be taken into consideration.

The basic load ratings stated are valid only in conjunction with a shaft as a mating track that is hardened (at least 670 HV) and ground (Ra 0,3).

### Fatigue limit load

The fatigue limit load  $C_{urW}$  is defined as the load below which – under laboratory conditions – no fatigue occurs in the material.

### Calculation of the rating life

The general methods for calculating the rating life are:

- the basic rating life in accordance with DIN ISO 281
- the adjusted rating life in accordance with DIN ISO 281
- the expanded calculation of the adjusted reference rating life in accordance with DIN ISO 281-4.

These methods are described in Catalogue HR 1, Rolling Bearings, in the chapter Load carrying capacity and rating life.

# Load carrying capacity and rating life

## Rating life of track rollers

In comparison with Catalogue HR 1, Rolling Bearings, the following values must be exchanged:

- $C_r = C_{rw}$
- $C_{0r} = C_{0rw}$
- $C_{ur} = C_{urw}$

The carriages LFCL, LFL...SF, LFL, LFKL...SF and bogie carriage LFDL contain four track rollers LFR.

The equivalent principle applies here. The corresponding parameters are taken into consideration in the basic load ratings  $C_y$ ,  $C_{0y}$ ,  $C_z$ ,  $C_{0z}$  and the permissible moment ratings  $M_{0x}$ ,  $M_{0y}$  and  $M_{0z}$ .

$C_y$	N
Basic dynamic load rating in y direction	
$C_{0y}$	N
Basic static load rating in y direction	
$C_z$	N
Basic dynamic load rating in z direction	
$C_{0z}$	N
Basic static load rating in z direction	
$M_{0x}$	Nm
Static moment rating about x axis	
$M_{0y}$	Nm
Static moment rating about y axis	
$M_{0z}$	Nm
Static moment rating about z axis.	

In the case of track rollers with a profiled outer ring, calculation is carried out exclusively by means of the basic rating life to DIN ISO 281.

*Figure 2*  
Load carrying capacity  
and load directions

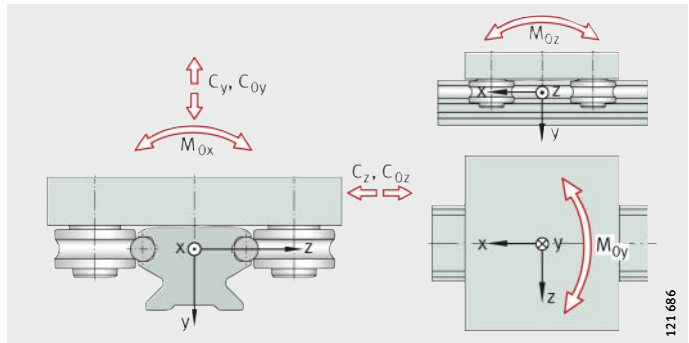





**Other formulae for calculating the basic rating life**

$$L_s = 0,0314 \cdot D_a \cdot \left( \frac{C_{rw}}{P_r} \right)^p$$

$$L_h = 26,18 \cdot \frac{D_a}{H \cdot n_{osc}} \cdot \left( \frac{C_{rw}}{P_r} \right)^p$$

$$L_h = 52,36 \cdot \frac{D_a}{\bar{v}} \cdot \left( \frac{C_{rw}}{P_r} \right)^p$$

**Rating life for carriages with four track rollers**

$$L_s = \left( \frac{C_y, C_z}{P} \right)^p$$

$$L_h = \frac{833}{H \cdot n_{osc}} \cdot \left( \frac{C_y, C_z}{P} \right)^p$$

$$L_h = \frac{1666}{\bar{v}} \cdot \left( \frac{C_y, C_z}{P} \right)^p$$

$L_s$   $10^5$  m

Basic rating life in metres

$D_a$  mm

Rolling contact diameter of track roller, see dimension tables

$C_{rw}, C_y, C_z$  N

Effective dynamic load rating

$P_r$  N

Equivalent dynamic load (radial load)

$p$  -

Ball:  $p = 3$ ;

needle roller (non-locating bearing track roller or carriage):  $p = 10/3$

$L_h$  h

Basic rating life in operating hours

$H$  m

Single stroke length for reciprocating motion

$n_{osc}$   $\text{min}^{-1}$

Number of return strokes per minute

$\bar{v}$  m/min

Mean travel velocity

$P$  N.

Equivalent dynamic load in the corresponding load direction (for applications with combined loads, please contact us).

# Load carrying capacity and rating life

## Operating life

The operating life is the life actually achieved by a rolling bearing. It may differ significantly from the calculated rating life.

This may be due to wear or fatigue as a result of:

- deviations in the operating data
- insufficient or excessive operating clearance (track roller, guideway)
- contamination
- inadequate lubrication
- operating temperature too high or too low
- reciprocating motion with very small stroke length, which can lead to false brinelling
- high vibration load, leading to false brinelling
- very high shock loads (static overloading)
- prior damage during mounting.

Due to the variety of mounting and operating conditions, the operating life cannot be precisely calculated in advance. The most reliable way of arriving at a close estimate is by comparison with similar applications.



## Static load safety factor

The indicator of static loading is the static load safety factor  $S_0$ . This indicates the security against impermissible permanent deformations in the bearing and is determined by means of the following equation:

$$S_0 = \frac{C_{0r w}}{F_{0r}}$$

## Static load safety factor for carriages with four track rollers

$$S_0 = \frac{C_0}{F_0}$$

$$S_0 = \frac{M_0}{M}$$

$S_0$	–
Static load safety factor	
$C_{0r w}$	N
Effective static load rating of track roller, see dimension tables	
$F_{0r}$	N
Static force acting in radial direction	
$C_0$	N
Basic static load rating of carriage, see dimension tables	
$F_0$	N
Static force acting in y and z direction	
$M_0$	Nm
Permissible static moment in x, y, z direction	
$M$	Nm
Moment acting in load direction ( $M_x, M_y, M_z$ ).	

Track rollers are regarded as heavily loaded at a static load safety factor of  $S_0 < 4$ .

For applications with normal operating conditions, a value  $S_0 > 4$  is required.

When using individual track rollers, for example in conjunction with guideways, the decisive factor where required is the permissible load of the guideway.



Static load safety factors  $S_0 < 1$  cause plastic deformation of the rolling elements and the raceway, which can impair smooth running. This is only permissible for bearings with small rotary motions or in secondary applications.

# Load carrying capacity and rating life

## Minimum load

In order to ensure that the outer ring is driven, that no slippage occurs and that the track roller does not lift from the mating track, the track rollers must be subjected to a minimum load in dynamic operation.



In general, the minimum load is calculated using the ratio  $C_{Orw}/F_r < 60$ .

## Differences in raceway hardness

If shafts with a lower surface hardness are used (such as X46, X90), a hardness factor must be applied, see equations and *Figure 3*.

$$C_H = f_H \cdot C$$

$$C_{OH} = f_{H0} \cdot C_0$$

$C_H$  Effective dynamic load rating

$f_H$  Dynamic hardness factor

$C$  Basic dynamic load rating

$C_{OH}$  Effective static load rating

$f_{H0}$  Static hardness factor

$C_0$  Basic static load rating.

$f_{H0}, f_H$  = hardness factor  
HV, HRC = surface hardness

① LFS..-RB, W..-X90

② W..-X46

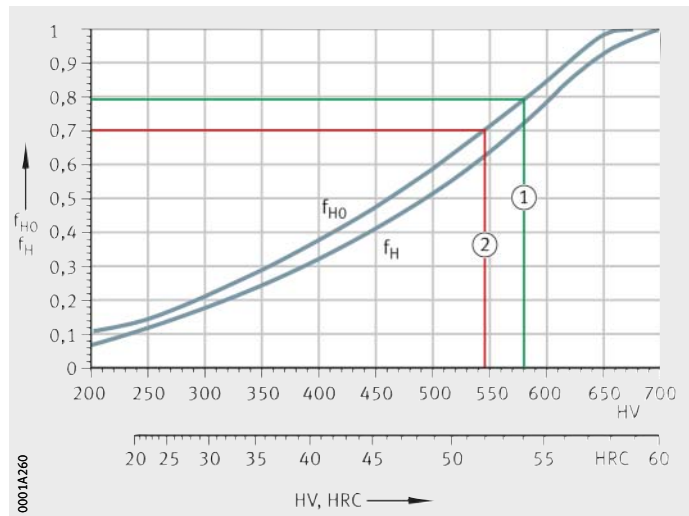

*Figure 3*

Static and dynamic hardness factors for lower hardness of raceways



# Lubrication

## Lubrication of guideway raceways

The guideway raceways must be lubricated (even before first use). Lubrication can be carried out by means of lubrication and wiper units.

These units are already integrated in the compact carriage LFKL...SF. For carriages LFL...SF and LFCL, the lubrication and wiper unit AB, see page 109, is available as an accessory.

The guideway raceway is lubricated by an oil-soaked felt insert. Oil can be fed to the felt inserts via lubrication nipples in the end faces. At delivery, the felt inserts are already soaked with oil (H1 approval for the food industry), where relubrication is to be carried out an oil of viscosity  $\nu = 460 \text{ mm}^2/\text{s}$  is recommended.

## Lubrication intervals

The lubrication intervals for guideway raceways are dependent on the environmental influences. The cleaner the environment, the smaller the quantity of lubricant required. The time and quantity can only be determined precisely under operating conditions since it is not possible to determine all the influences by calculation. An observation period of adequate length must be allowed.



Fretting corrosion is a consequence of inadequate lubrication and is visible as a reddish discolouration of the mating track or outer ring. Inadequate lubrication can lead to permanent system damage and therefore to failure. It must be ensured that the lubrication intervals are reduced accordingly in order to prevent fretting corrosion.

In general, a thin film of oil should always be present on the shaft.

## Lubrication of track rollers

At delivery, track rollers LFR have an initial greasing of a high quality lithium soap grease.

From LFR5204-16, the inner ring has a relubrication hole. Track rollers of smaller diameters are lubricated for life.

# Lubrication

## Further information on lubrication

Further information can be found in Catalogue HR 1, Rolling Bearings, in the chapter Lubrication.

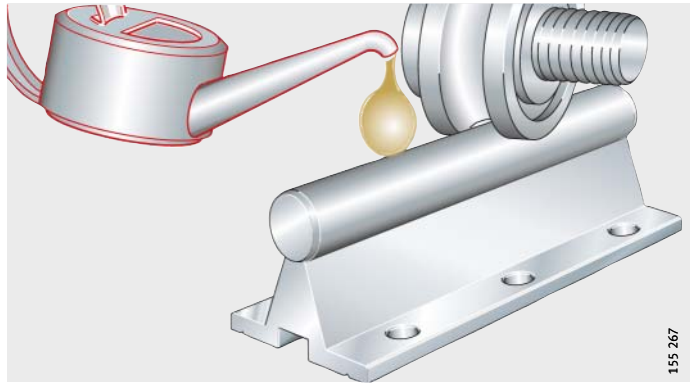

*Figure 1*  
Lubrication of guideway raceways



# Design of bearing arrangements

## Requirements for the adjacent construction

The running accuracy of the linear guidance system is essentially dependent on the straightness, accuracy and rigidity of the mounting surfaces.

The higher the requirements for accuracy and smooth running of a track roller guidance system, the more attention must be paid to the geometrical and positional accuracy of the adjacent construction. The adjacent surfaces should be flat and have parallel faces.

For two guideways, we recommend a parallelism according to *Figure 1*.

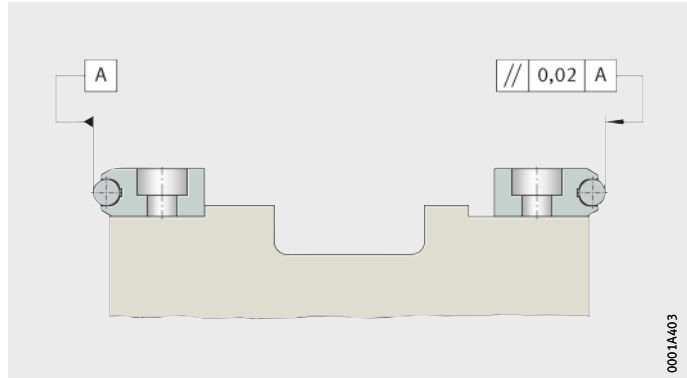

*Figure 1*  
Parallelism of guideways

## Shaft creep

Under unfavourable conditions, shaft creep of a few millimetres may occur in isolated cases. This creep may occur mainly in applications with high accelerations in conjunction with high alternating loads and guideways that are not completely supported. It may also be caused by an adjacent construction that is too soft.

In such cases, shaft creep can be prevented by the use of end plates ANS.LFS, see dimension table page 115. They can be supplied already mounted.

## Displacement force

The displacement force is dependent on the preload, the lubrication and the particular application. It is therefore not possible to make generally valid statements.

# Design of bearing arrangements

## Location of carriages and guideways

If lateral loads are present, it is recommended that the guideways and carriages should be located against locating surfaces. In the case of guideways comprising multiple sections joined together, it is recommended that the guideways should be aligned by means of the shaft. If necessary, the shafts should be located on the adjacent construction by means of dowels.

If two guideways are arranged in parallel, the first guideway should be clamped against a stop, *Figure 1*, page 21. The second guideway should then be aligned accordingly. Any gaps between the guideway and the adjacent construction should be filled with synthetic resin.

## Track roller guidance systems in accordance with customer specifications

The INA track roller guidance systems with curved guideway elements can be used to achieve an extremely wide variety of applications, *Figure 2* and *Figure 3*, page 23.

If the arrangement required cannot be represented using the standard ordering designation, a customer drawing must be submitted with the enquiry.

For arrangements with curved guideway elements, it is recommended that the guideway connectors VBS should be used at the joints, see page 114. This gives considerably easier mounting.



Standard oval tracks are always supplied with guideway connectors VBS, see page 102.

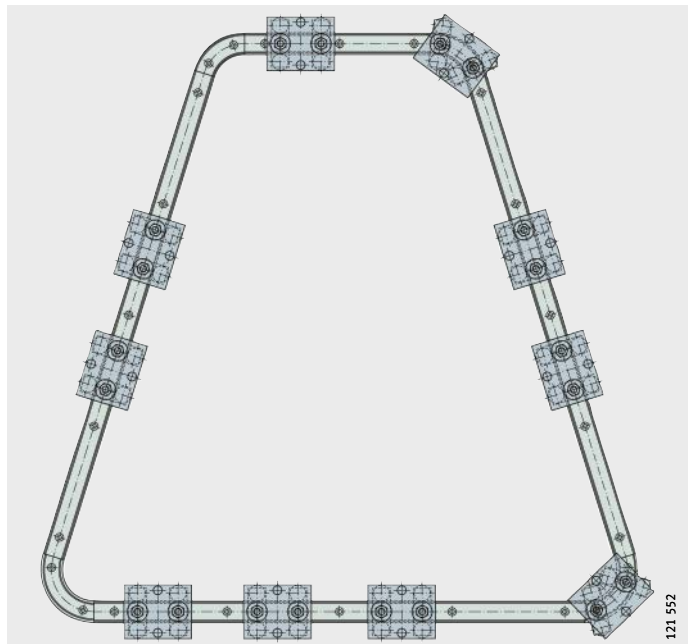

*Figure 2*  
Arrangement according to customer requirements



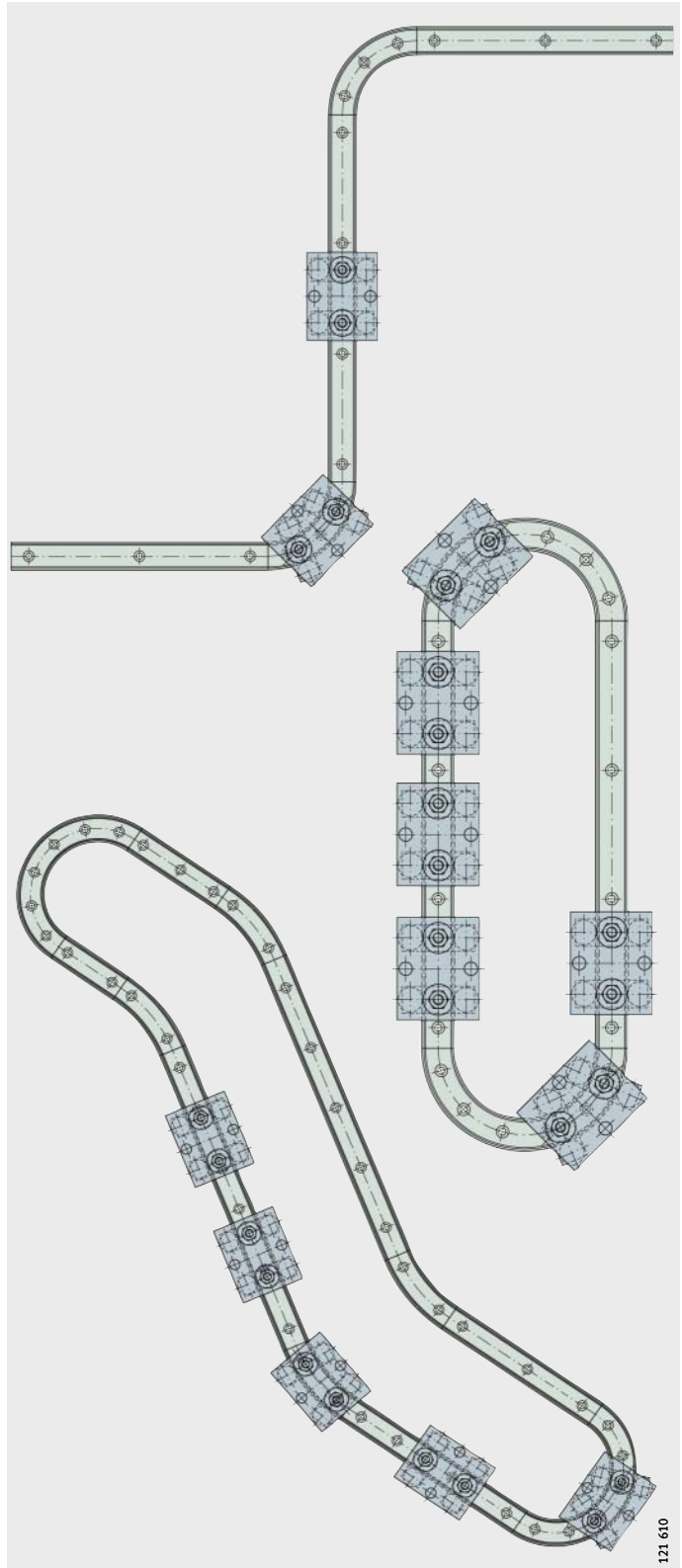
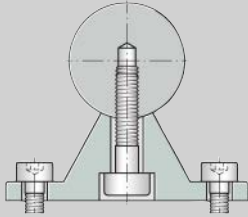

*Figure 3*  
Closed and open applications  
with guidance systems including  
curved guideway elements

121 610

# Design of bearing arrangements

## Possible combinations of profiled track rollers with guideways

		Guideways		
				
Shaft diameter mm	TSNW, TSNW..-G4 (-G5) Fixing screw	Load case, <i>Figure 4</i>		
		I	II	III
12	DIN ISO 4762	■	–	–
	DIN 7984	■	■	■
16	DIN ISO 4762	■	–	–
	DIN 7984	■	–	–
20	DIN ISO 4762	■	–	–
	DIN 7984	■	–	–
25	DIN ISO 4762	■	■	■
	DIN 7984	■	■	■
30	DIN ISO 4762	■	–	–
	DIN 7984	■	■	■
40	DIN ISO 4762	■	■	■
	DIN 7984	■	■	■
50	DIN ISO 4762	■	■	■
	DIN 7984	■	■	■

- combination possible if the rail is located using the stated screw
- combination possible
- combination possible if  $t \leq t_{\max}$  and  $b \leq b_{\max}$
- please contact us

1) With AB.W:  $t_{\max} = 2,5$ .

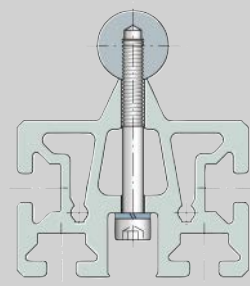
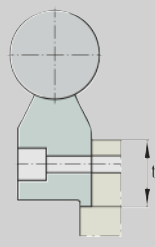
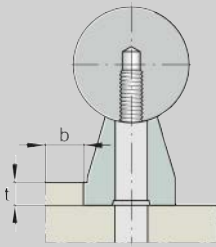

TSUW					TSSW				TSMW		
t <sub>max</sub> mm	b <sub>max</sub> mm	Load case, Figure 4			t <sub>max</sub> mm <sup>1)</sup>	Load case, Figure 4			Load case, Figure 4		
		I	II	III		I	II	III	I	II	III
5	5	●		○ <sup>1)</sup>	-	-	-	-	-	-	-
-	-	●	-	-	-	-	-	-	-	-	-
-	-	●	-	-	-	●	-	-	●	-	-
10	12	●	●	○	36	●	●	●	●	●	●
12	16	●	●	○	42	●	●	●	●	●	●
10	-	●	●	○	50	●	●	●	-	-	-
13	-	●	●	○	70	●	●	●	-	-	-



- For the combination, take account of:
- the static load safety factor  $S_0$ , see page 17
  - the load cases, Figure 4
  - a shaft hardness of 670 HV.

$$S_0 = C_{0w}/P_0$$

Figure 4  
Load cases I, II and III

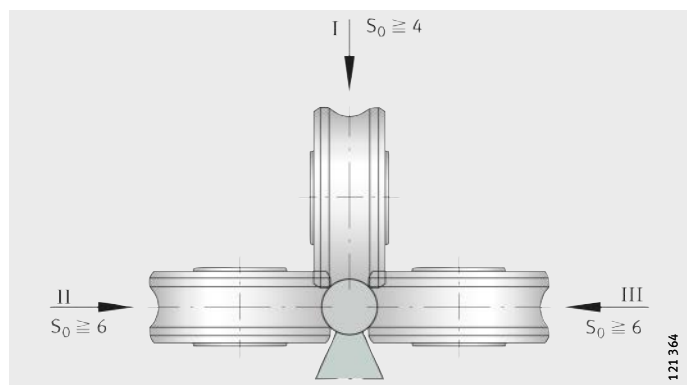

# Mounting

## Delivered condition

Carriages are delivered with the track rollers fitted. All the bolts are tightened to the required tightening torque.

## Carriages

For carriages, this gives:

- hollow section carriage LFCL; clearance-free, with mounting of accessories as necessary
- compact carriage LFKL..-SF; clearance-free, with mounting of lubrication and wiper unit as necessary
- non-locating bearing carriage LFLL..-SF; clearance-free, with mounting of accessories as necessary
- open carriage LFL..-SF; clearance-free, with mounting of accessories as necessary
- bogie carriage LFDL..-SF (-B); LFDL..-SF clearance-free, with mounting of accessories as necessary. In the case of LFDL..-B, the clearance must be set by means of eccentrics.

## Mounting of guidance system with one guideway

Mounting of guidance system with one guideway:

- Place the guideway on the adjacent construction and screw mount finger tight.
- Align the guideway; if necessary, clamp the shaft against the locating edge and screw mount firmly, observing the tightening torques.
- Clearance-free carriages: slide the carriage onto the guideway.
- Carriages with adjustable clearance: if lateral load is present, ensure that the principal load is supported by the concentric bolts.
- Position and screw mount the adjacent construction.



## Mounting of guidance system with two guideways

Mounting of guidance system with two guideways:

- Position the first guideway, clamp it against the locating edge and tighten the screws.
- Position the second guideway and screw mount finger tight.
- Slide the carriage onto the guideway, set the clearance as necessary, *Figure 2*, page 28.
- Position the adjacent construction, align the carriage and screw mount firmly; observe the tightening torques  $M_A$ , see table, page 29.
- Align the second guideway with the aid of the table, move the table several times during this operation.
- Tighten the fixing screws in the guideway; tightening torques  $M_A$ , see table, page 29.

Where necessary, form fit can be achieved between the guideways and adjacent construction by means of synthetic resin or strips.

## Mounting of curved guideway elements and oval tracks

Mounting of curved guideway elements and oval tracks:

- Assemble the curved guideway elements or oval tracks.
- Position the assembled elements precisely on the adjacent construction and fix in place by means of clamps.
- Transfer the hole pattern for the fixing holes to the adjacent construction.
- Remove the elements and make the fixing holes in the adjacent construction.
- Position the elements on the adjacent construction again and tighten the fixing screws; observe the tightening torques  $M_A$ , see table, page 29.

## Mounting of bogie carriage

Slide the clearance-free carriage LFDL..-SF onto the guideway. No setting of clearance is required, *Figure 1*, page 28.



The bogie carriage LFDL..-SF cannot be mounted on closed ring systems, in this case use the clearance-free bogie carriage LFDL..-B.

## Carriages with adjustable clearance

Slide the carriage LFDL..-B onto the guideway and set in position without load. Rotate the eccentric bolts using an open-end wrench or ring wrench so that the track rollers are set against the raceway, observing the direction of rotation, *Figure 2*, page 28.

Tighten the hexagon nuts to the tightening torque  $M_A$ ; tightening torques, see table, page 29.



The track rollers must be easily movable and clearance-free. If they are set in place too firmly, this will generate preload that reduces the life of the guidance system.

# Mounting

## Inspection

Check the adjustment. The guidance system is correctly adjusted if, when the carriages are moved, all the track rollers rotate and the carriages can be moved easily.

The concentric bolts are tightened to the necessary tightening torque, the eccentric bolts are tightened finger tight. When setting the preload, these must be tightened to the tightening torque  $M_A$ , see table Tightening torques for track roller bolts, page 29.



*Figure 1*  
Clearance-free carriage LFDL...SF

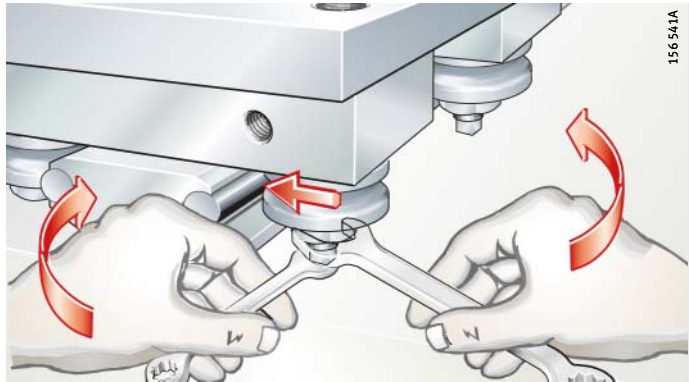

*Figure 2*  
Carriage with adjustable  
clearance LFDL...B



**Tightening torques  
for track roller bolts**

Track roller, profiled track roller	Bolt	Tightening torque $M_A$	
		Standard (-2Z) Nm	RB (-2RSR) Nm
LFR50/5-4	M4	2,5	2,5
LFR50/5-6	M4	2,5	2,5
LFR50/8-6	M8	15	12
LFR5201-10	M10	40	23
LFR5301-10	M10	40	23
LFR5302-10	M12	70	39
LFR5201-12	M10	40	23
LFR5204-16	M16×1,5	100	75
LFR5206-20	M20×1,5	200	100
LFR5206-25	M20×1,5	200	100
LFR5207-30	M24×1,5	300	150
LFR5208-40	M30×1,5	600	310
LFR5308-50	M30×1,5	800	410

**Tightening torques  
for screws in carriage  
according to DIN ISO 4762-8.8**

Screw	Tightening torque $M_A$ Nm
M5	5,8
M6	9,9
M8	24
M10	48
M12	83

**Tightening torques  
for screws in guideways LFS  
according to DIN ISO 4762-8.8 or  
DIN 7984-8.8**

Screw	Tightening torque $M_A$ Nm
M5	5,8
M6	9,9
M8	24
M10	48
M12	83

# Accuracy

## Accuracy of guideways LFS

Data on the straightness, parallelism (differential measurement), length and positional tolerances of guideways are given in the following tables and figures, *Figure 1 to Figure 5*, page 32.

The guideways are precision straightened and the tolerances are better than DIN EN 12020.

### Length tolerance

Length L mm		Tolerance mm
Single-piece guideways	$L < 1\,000$	$\pm 2$
	$1\,000 \leq L < 2\,000$	$\pm 3$
	$2\,000 \leq L < 4\,000$	$\pm 4$
	$4\,000 \leq L$	$\pm 5$
Multi-piece guideways	Total length L	$\pm 0,1\%$

### Straightness tolerance for guideways

Length of guideway	Tolerance	
	$t_1$ (contact face) mm	$t_2$ (lateral) mm
$L < 1\,000$	0,5	0,2
$1\,000 \leq L < 2\,000$	1	0,3
$2\,000 \leq L < 3\,000$	1,5	0,4
$3\,000 \leq L < 4\,000$	2	0,5
$4\,000 \leq L < 5\,000$	2,5	0,6
$5\,000 \leq L < 6\,000$	3	0,7
$6\,000 \leq L < 7\,000$	3,5	0,8
$7\,000 \leq L < 8\,000$	4	0,9

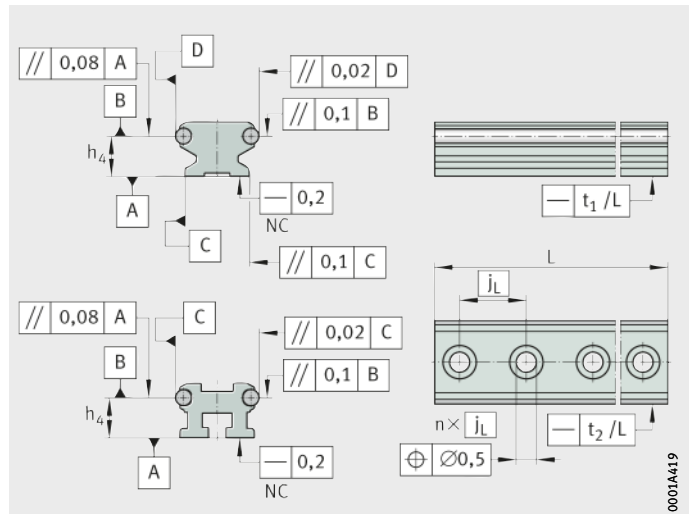

*Figure 1*  
Tolerances for guideways  
LFS, LFS..-C, LFS..-NZZ, LFSR..-ST



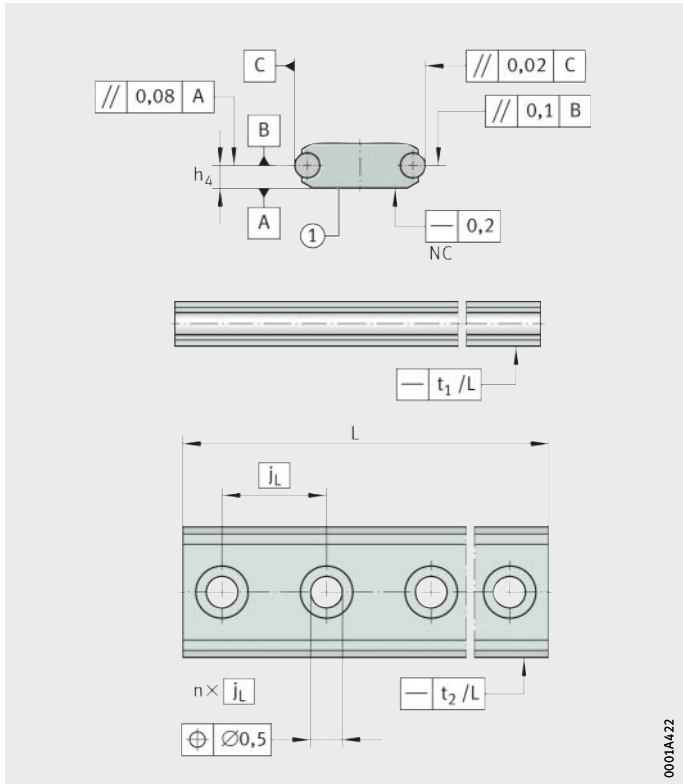

① Contact face indicated by slot

Figure 2  
Guideway LFS..-F

0001A4.22

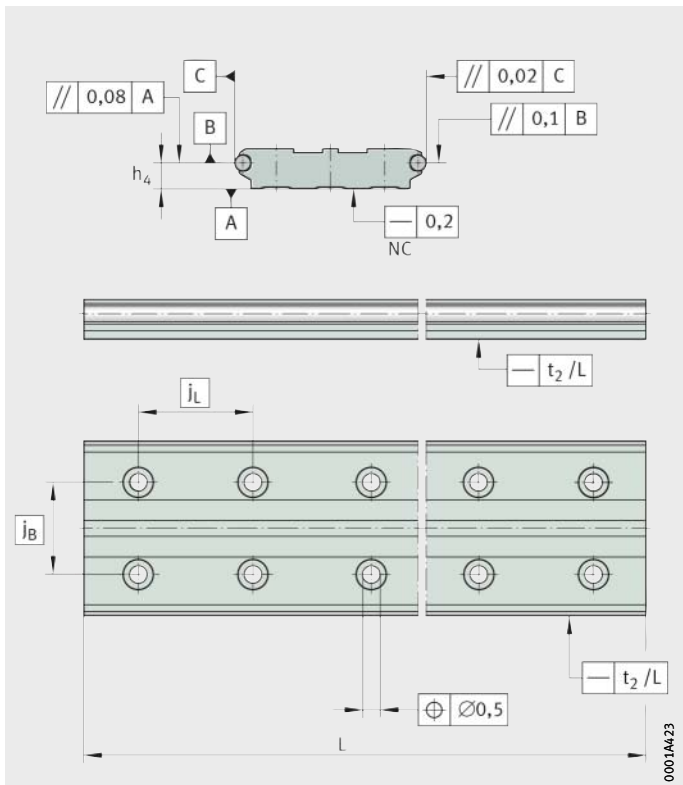

Parallelism determined  
by differential measurement

Figure 3  
Guideway LFS120

0001A4.23

# Accuracy

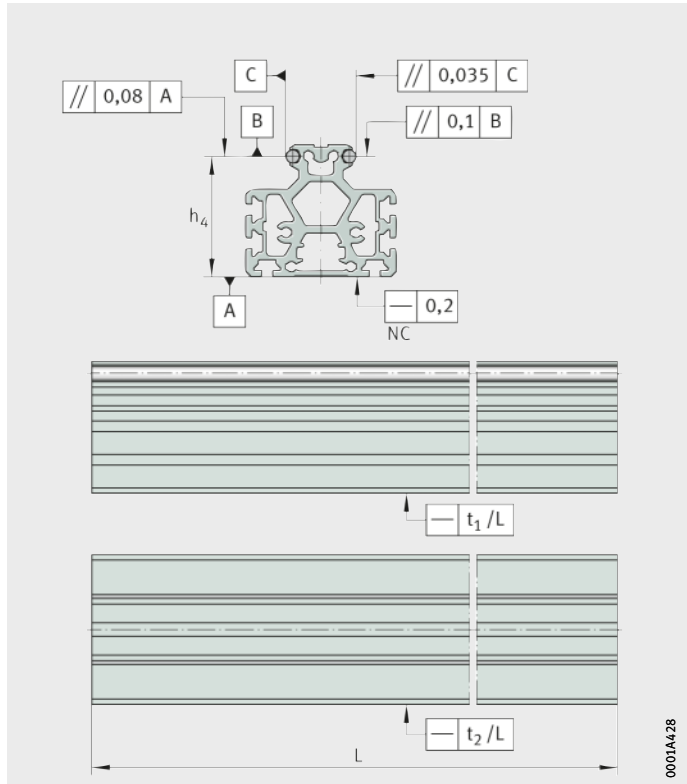

Parallelism determined by differential measurement

Figure 4  
Guideway LFS..-M

0001A428

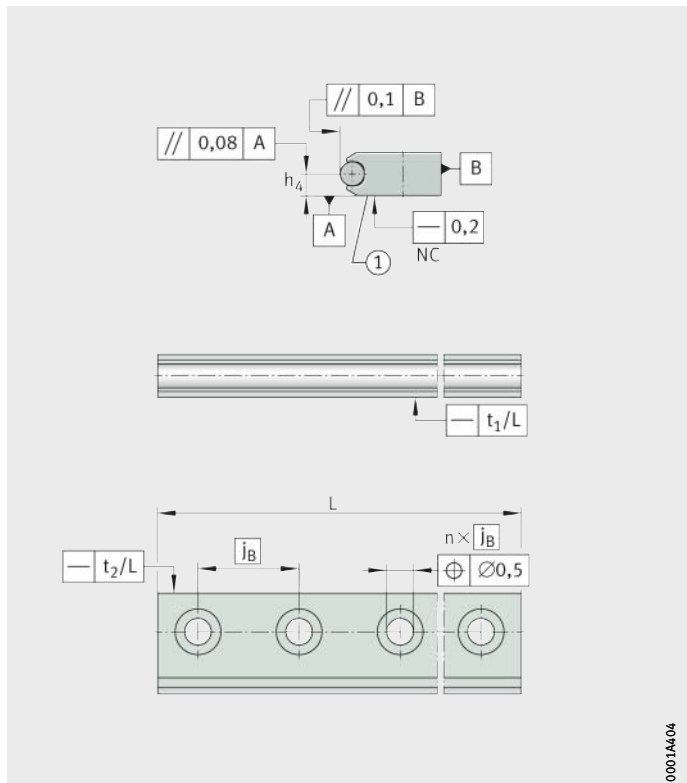

① Contact face indicated by slot

Figure 5  
Guideway LFS..-FH

0001A404



**Tolerances for  $H_2$  and  $h_4$**

Tolerances for  $H_2$  and  $h_4$ , see table, *Figure 6* and *Figure 7*.

Guideway	Tolerance for	
	$H_2$ mm	$h_4$ mm
LFS20	+0,3	-0,1
LFS25		-0,1
LFS25-M		$\pm 0,25$
LFS32		+0,2
LFS32-C		+0,2
LFS32-N		+0,2
LFS32-F		+0,1
LFS32-M		$\pm 0,25$
LFS32-FH		+0,1
LFS42-C		+0,2
LFS42-F		+0,1
LFS52		+0,2
LFS52-C		+0,2
LFS52-NZZ		+0,2
LFS52-F		+0,1
LFS52-M		+0,5
LFS52-FH		+0,1
LFS86-C		+0,25
LFS120		+0,2

Tolerance for  $H_2 = +0,3$  mm

*Figure 6*  
Reference dimension for accuracy,  
dimension  $H_2$

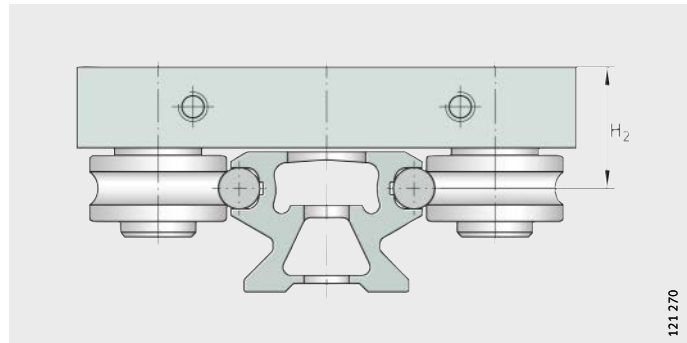

121 270

*Figure 7*  
Reference dimension for accuracy,  
dimension  $h_4$

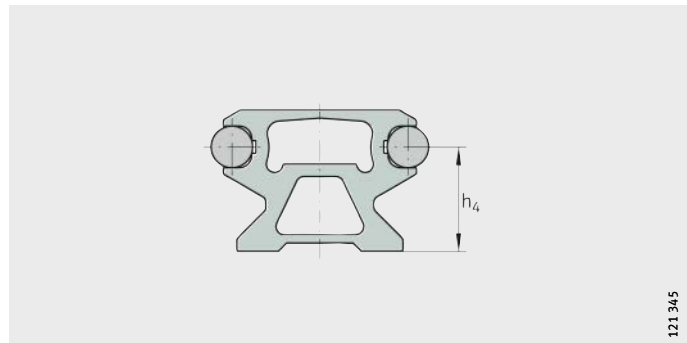

121 345

## Ordering example, ordering designation

### Ready-to-fit systems

The elements of the track roller guidance systems (such as the carriage, guideway) must be ordered separately.

Carriages should be regarded as a unit, including the track rollers and bolts.

Carriages and guideways can be used in any combination and can be ordered independently of each other.

### Ordering example

Track roller guidance system of corrosion-resistant design with open carriage LFL52-E-SF, *Figure 1* and *Figure 2*.

Carriage	Carriage	LFL
	Size	52-E
	Clearance-free	SF
	Corrosion-resistant	RB

Ordering designation **LFL52-E-SF-RB**

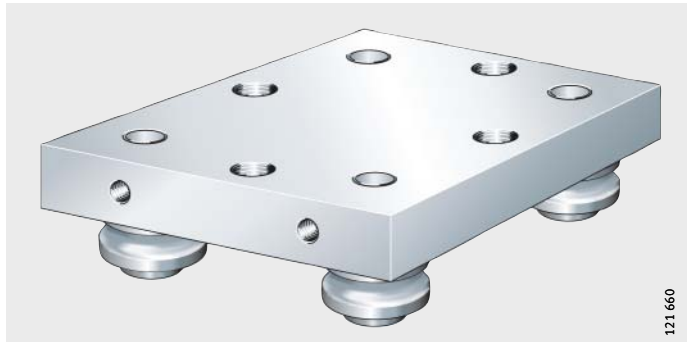

*Figure 1*  
Open carriage LFL52-E-SF

121 660



Guideway Hollow section guideway LFS52-CE, length 1500 mm,  $a_L = 50$  mm,  $a_R = 75$  mm, corrosion-resistant design, *Figure 2*:

Guideways	LFS
Width of guideway	52 mm
Length of guideway l	1500 mm
Design	CE
Corrosion-resistant	RB
Spacing $a_L$	50 mm
Spacing $a_R$	75 mm

Ordering designation **LFS52×1500-CE-RB-50/75**

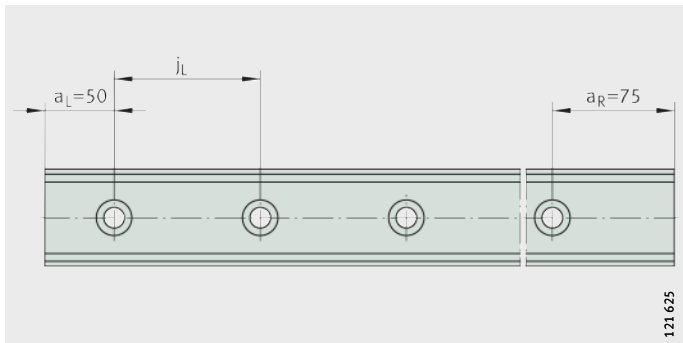

*Figure 2*  
Guideway LFS52-CE

121.625

# Ordering example, ordering designation

## Closed oval tracks

Oval track with two 180° arcs

Guideways	LFS
Width of guideways $b$	52 mm
Length of straight guideways	2 000 mm
Closed oval track	OV
Radius of arc $r$	300 mm

Ordering designation

Without guideway connectors VBS, *Figure 3*

**1×LFS52×2000-OV-300**

With guideway connectors VBS, *Figure 4*

**1×LFS52×2000-OV-300-VBS**

$b$  = width of guideways  
 $r$  = radius of arc

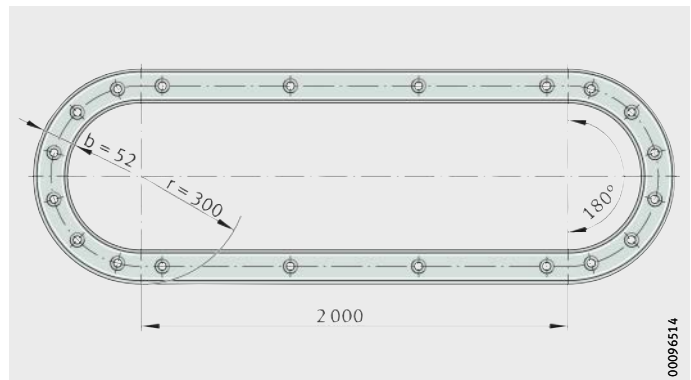

*Figure 3*

Closed oval track with 180° arcs  
 LFS52×2000-OV-300

$b$  = width of guideways  
 $r$  = radius of arc

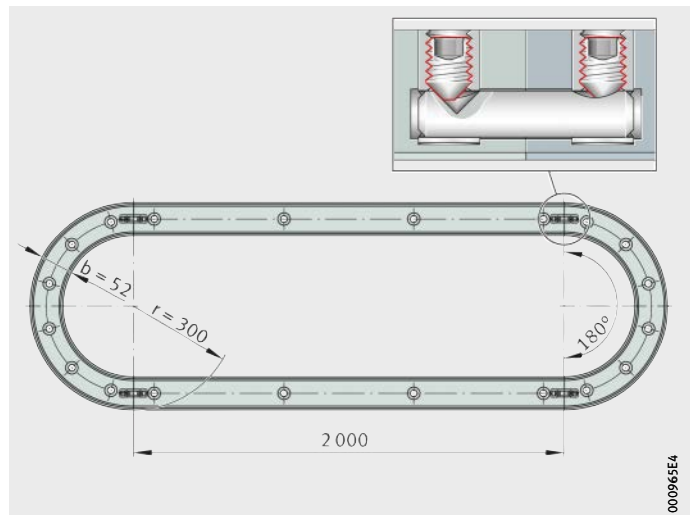

*Figure 4*

Closed oval track with 180° arcs and  
 guideway connectors VBS  
 LFS52×2000-OV-300-VBS



Oval track with four 90° arcs

Guideways	LFS
Width of guideways b	52 mm
Length of straight guideways	
1st straight guideway	2 000 mm
2nd straight guideway	3 000 mm
Closed oval track	OV
Radius of arc r	300 mm

Ordering designation

Without guideway connectors VBS, *Figure 5*  
**1×LFS52×2000×3000-OV-300**

With guideway connectors VBS, *Figure 6*  
**1×LFS52×2000×3000-OV-300-VBS**

b = width of guideways  
 r = radius of arc

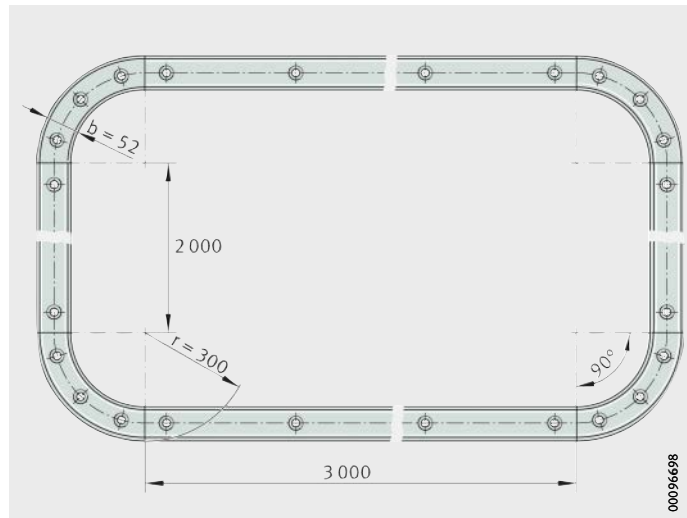

*Figure 5*  
 Closed oval track with 90° arcs  
 LFS52×2000×3000-OV-300

b = width of guideways  
 r = radius of arc

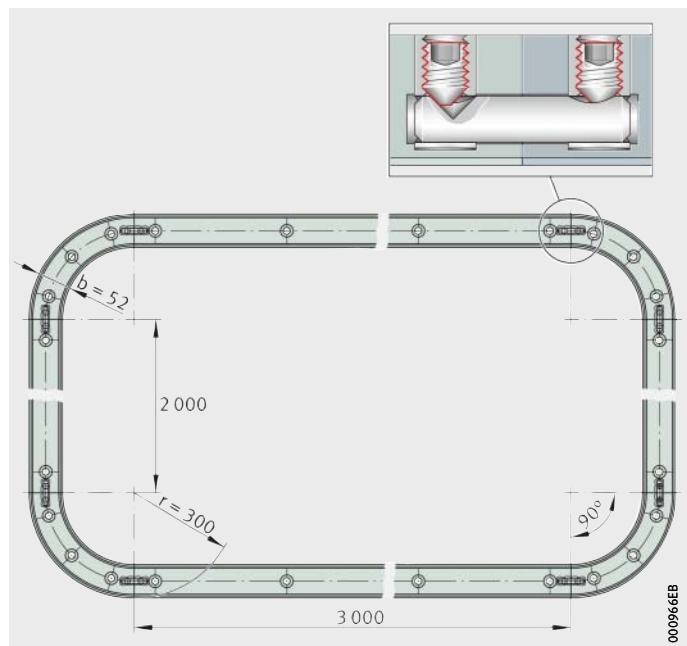

*Figure 6*  
 Closed oval track with 90° arcs and  
 guideway connectors VBS  
 LFS52×2000×3000-OV-300-VBS

## Ordering example, ordering designation

### Individual components

In order to achieve versatile user designs, it is also possible to order individual components of the ready-to-fit systems; example, *Figure 7*.

Track roller	Series	LFR
	Size	50/8-6
	Sealing	2RS
	Corrosion-resistant	RB, <i>Figure 7</i>
Ordering designation	<b>LFR50/8-6-2RS-RB</b>	
Bolt	Series	LF
	Concentric	Z
	Size	8
	Corrosion-resistant	RB, <i>Figure 7</i>
Ordering designation	<b>LFZ8-RB</b>	
Cap wiper	Series	AB.LFR
	Size	50/8, <i>Figure 7</i>
Ordering designation	<b>AB.LFR50/8</b>	

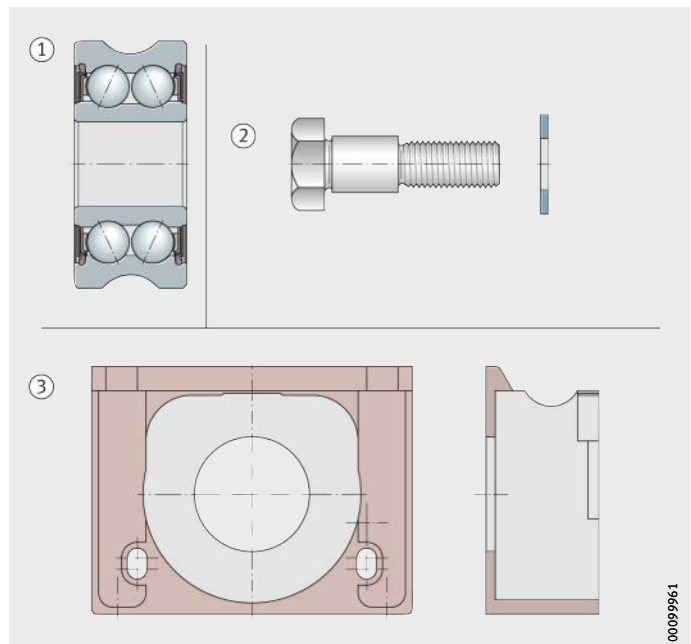

- ① Track roller
- ② Bolt, concentric
- ③ Cap wiper

*Figure 7*  
Track roller, bolt, wiper





## Operating limits

- Operating temperature** Track roller guidance systems can be used at a temperature from  $-20\text{ °C}$  to  $+80\text{ °C}$ . For applications below  $-20\text{ °C}$  and above  $+80\text{ °C}$ , please contact us.  
The area of application is restricted by the lubricant, the plastics used and the composite materials.
- Velocities** The maximum possible speed of track roller guidance systems is  $10\text{ m/s}$ . Higher speeds may be possible by agreement.
- Acceleration** When using track roller guidance systems, accelerations of up to  $50\text{ m/s}^2$  can be achieved.

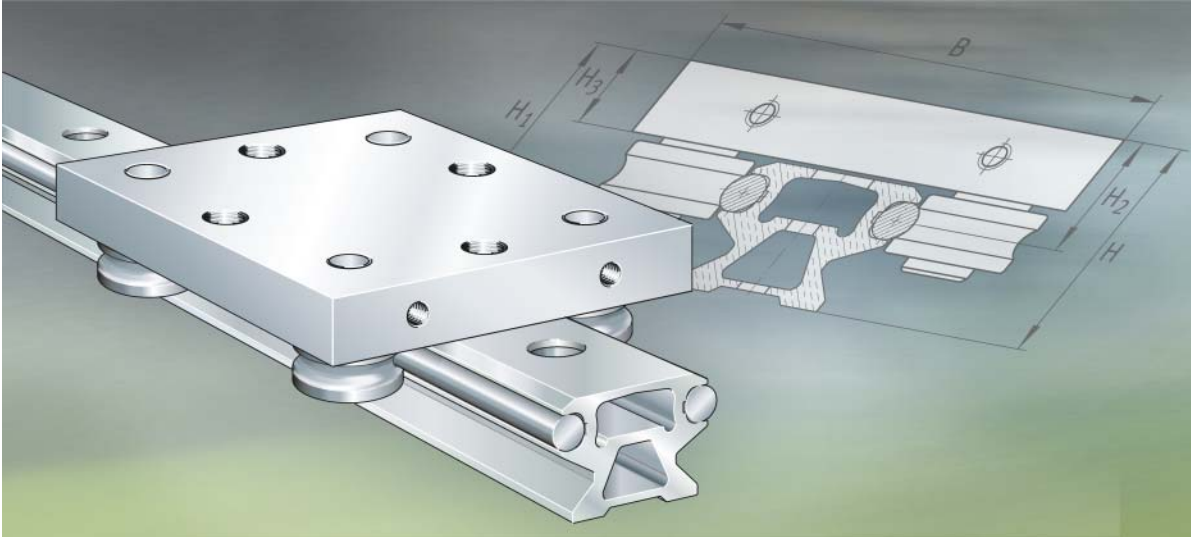

## Track roller guidance systems





- With hollow section carriage
- With compact carriage
- With open carriage
- With non-locating bearing carriage
- With bogie carriage

# Track roller guidance systems

		Page
<b>Matrix</b>	Matrix for preselection of track roller guidance systems.....	42
<b>Product overview</b>	Track roller guidance systems .....	44
<b>Features</b>	Track roller guidance systems	
	With hollow section carriage .....	46
	With compact carriage.....	48
	With open carriage .....	50
	With non-locating bearing carriage .....	52
	With bogie carriage .....	54
<b>Dimension tables</b>	Track roller guidance systems	
	With hollow section carriage .....	56
	With compact carriage.....	58
	With open carriage .....	60
	With non-locating bearing carriage .....	62
	With bogie carriage .....	64

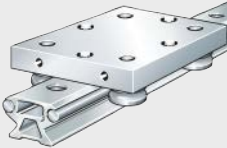

**Matrix for preselection  
of track roller guidance systems**

Track roller guidance systems with	Width of guideways						Corrosion- resistant
	20	25	32	42	52	86	
<b>Hollow section carriage LFCL</b> 	-	●	-	●	-	●	■
<b>Compact carriage LFKL...-SF</b> 	●	●	●	-	●	-	■
<b>Open carriage LFL...-SF</b> 	●	-	●	-	●	-	■
<b>Non-locating bearing carriage LFL...-SF</b> 	-	-	●	-	●	-	■
<b>Bogie carriage LFDL...-SF LFDL...-B</b> 	-	-	●	-	●	-	■

● available sizes

■ possible

1) The guideway LFS...-M can only be combined with carriages with adjustable clearance. If carriages LFCL and LFKL...-SF are to be used, please contact us in advance.

Special features of guidance systems	Sizes	Basic dimensions of guidance systems, dimensions, <i>Figure 1</i>									Description
		LFS (-C, -CE, -CEE, -E, -EE, -NZZ, -OV), LFSR..-ST			LFS..-F (-FE)			LFS..-M <sup>1)</sup>			
		H	B	L	H	B	L	H	B	L	
<ul style="list-style-type: none"> <li>■ economical</li> <li>■ low mass</li> <li>■ high moment load carrying capacity <math>M_x</math></li> </ul>	25	32,1	80	110	–	80	110	63,1	80	110	46
	42	39	116	150	33,9	116	150	–	116	150	
	86	59	190	235	–	190	235	–	190	235	
<ul style="list-style-type: none"> <li>■ closed series</li> <li>■ protected track rollers</li> <li>■ integrated lubrication unit</li> </ul>	20	22	56	69	–	56	69	–	56	69	48
	25	25	65	85	–	65	85	56	65	85	
	32	35,5	86	112	25,5	86	112	–	86	112	
	52	54,3	13	136	38,2	130	136	118,9	130	136	
	52-E	60,4	145	186	44,3	145	186	125	145	186	
	52-EE	60,4	155	205	44,3	155	205	125	155	205	
<ul style="list-style-type: none"> <li>■ very robust</li> <li>■ simple construction</li> </ul>	20	22	55	50	–	55	50	–	55	50	50
	32	35,5	80	90	25,5	80	90	81,5	80	90	
	52	54,3	120	100	38,2	120	100	118,9	120	100	
	52-E	60,4	135	150	44,3	135	150	125	135	150	
<ul style="list-style-type: none"> <li>■ locating and non-locating bearing arrangement</li> <li>■ compensation of skewing in the adjacent construction up to <math>\pm 1</math> mm</li> </ul>	32	35,5	80	90	25,5	80	90	81,5	80	90	52
	52	54,3	120	100	38,2	120	100	118,9	120	100	
<ul style="list-style-type: none"> <li>■ oval track guidance systems for unlimited stroke length</li> </ul>	32-B	44,2	80	100	34,2	80	100	90,2	80	100	54
	32-SF	44,2	80	100	34,2	80	100	90,2	80	100	
	52-B	66,1	120	150	50	120	150	130,7	120	150	
	52-SF	60,1	120	150	50	120	150	130,7	120	150	

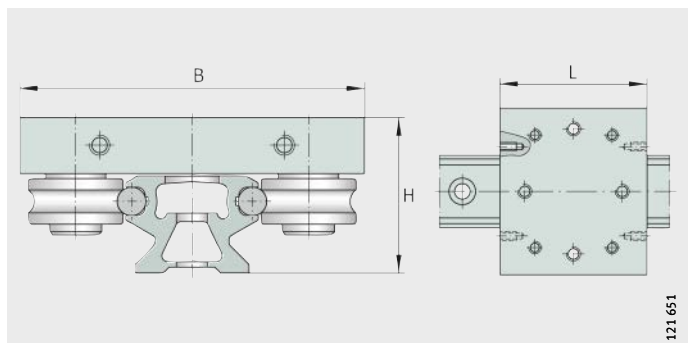

Figure 1  
Dimensions H, B, L

121 651

# Product overview Track roller guidance systems

**With hollow section carriage**  
Clearance-free

LFCL

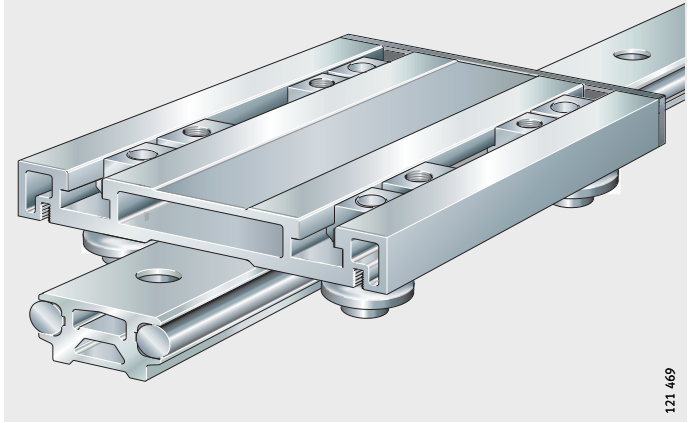

**With compact carriage**  
Clearance-free

LFKL...SF

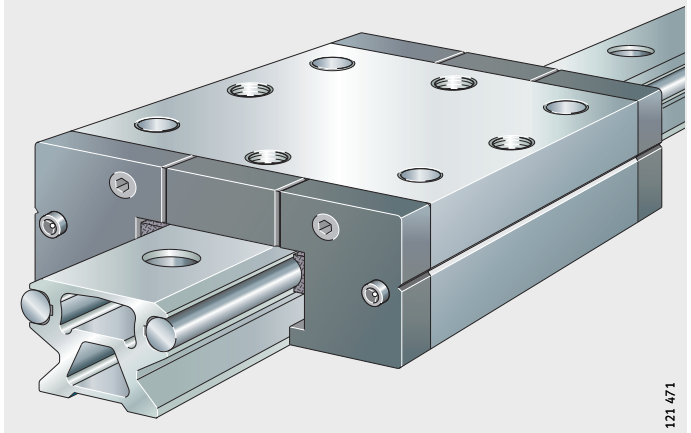

**With open carriage**  
Clearance-free

LFL...SF

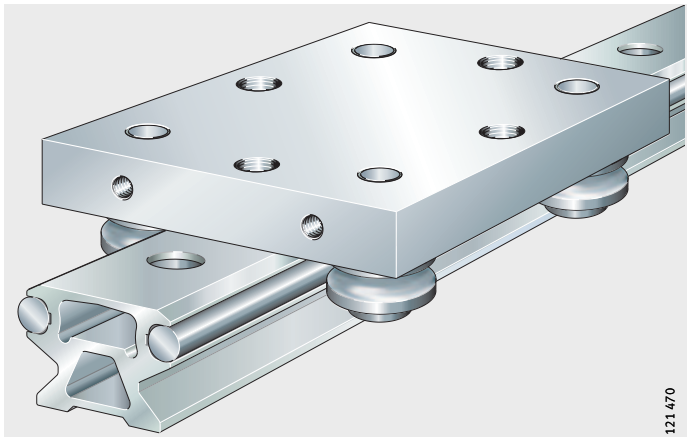

**With non-locating bearing carriage**  
Clearance-free

LFLL...-SF

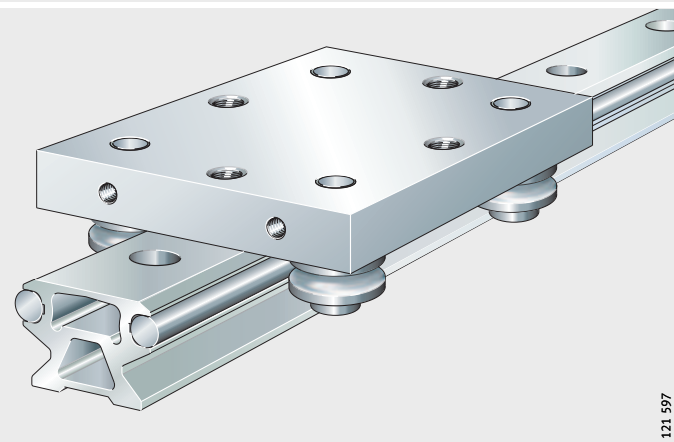

121 597

**With bogie carriage**  
Concentric and eccentric bolts,  
adjustable clearance

LFDL...-B

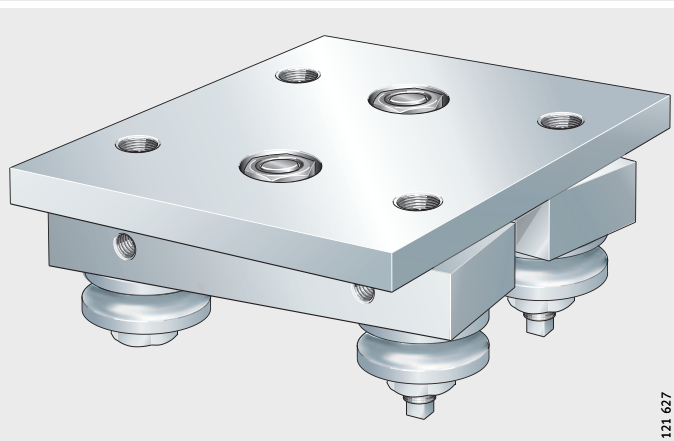

121 627

Concentric bolts  
clearance-free

LFDL...-SF

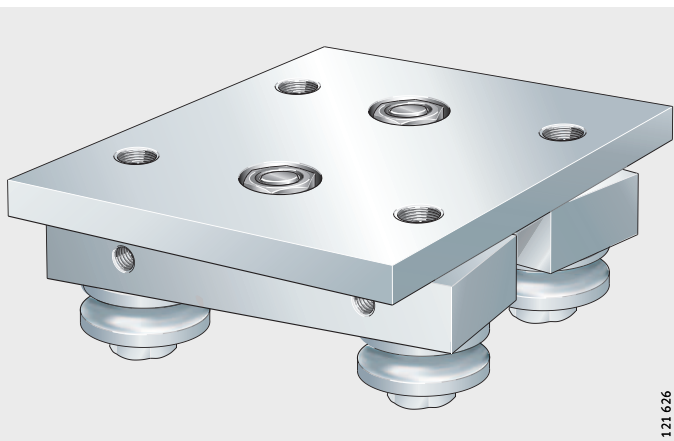

121 626

# Track roller guidance systems

## Features

Track roller guidance systems are available with a hollow section carriage, compact carriage, open carriage, non-locating bearing carriage or bogie carriage.

## Track roller guidance system with hollow section carriage

The economical series LFCL is characterised in particular by its low mass and its high moment load carrying capacity  $M_x$ . In addition, more individual design of the adjacent construction is possible by means of four T-bolts that can be moved in a longitudinal direction. A carriage comprises a carriage plate made from anodised aluminium, four concentric bolts, four track rollers, two end covers for the hollow sections and four T-nuts that can be used for the adjacent construction, *Figure 1*. The track rollers and end covers are already fitted.

- ① T-nut
- ② End cover
- ③ Carriage plate
- ④ Track roller
- ⑤ Concentric bolt

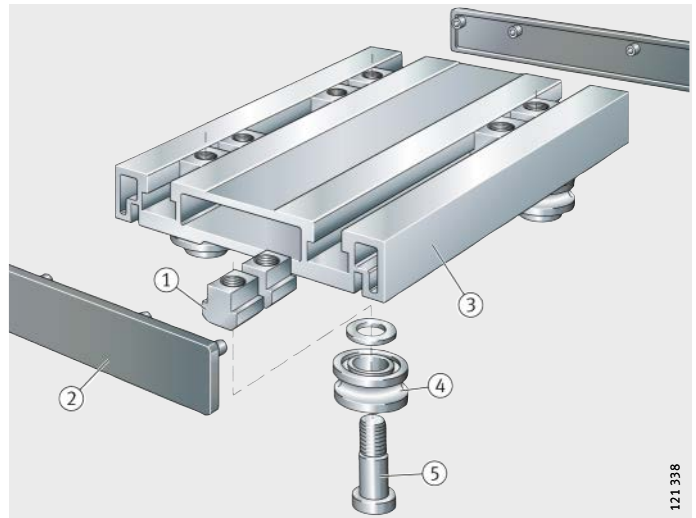

*Figure 1*  
Hollow section carriage

121\_338



<b>Preload and clearance</b>	The carriages run clearance-free on all INA guideways, see page 42, and can be combined with all guideways of the relevant size, but not with the curved guideway elements LFSR. Due to the highly accurate guideways, it is not necessary to set the clearance.
<b>Sealing and lubrication</b>	<p>The track rollers have gap seals on both sides, are greased for life and are therefore maintenance-free.</p> <p>The raceways can be lubricated using cap wipers AB.LFR. Their fixing screws pass into the screw mounting channels of the carriage plate.</p>
<b>Corrosion-resistant design</b>	All steel parts, the inner and outer rings of the track rollers and the bolts, washers and nuts are made from corrosion-resistant steel. The rolling elements are protected against corrosion by the grease. Corrosion-resistant designs have the suffix RB.
<b>Further information</b>	<p>Further information is given on the following pages:</p> <ul style="list-style-type: none"> <li>■ dimension table, see page 56</li> <li>■ track rollers, see page 68</li> <li>■ guideways, see page 76</li> <li>■ accessories, see page 106.</li> </ul>



## Track roller guidance systems

### Track roller guidance system with compact carriage

The closed compact carriage LFKL...-SF gives a simple means of achieving track roller guidance systems for operation in contaminated environments. The track rollers are protected against contamination by the closed design. It has two integrated lubrication units for lubrication of the raceways.

A carriage comprises a saddle plate made from anodised, profiled aluminium, four concentric bolts, four track rollers, two sealing strips and two lubrication and wiper units, *Figure 2*. The track rollers are already fitted, the sealing strips as well as the lubrication and wiper units are included loose in the delivery.

- ① Sealing strip
- ② Lubrication and wiper unit
- ③ Track roller
- ④ Concentric bolt
- ⑤ Saddle plate

*Figure 2*  
Compact carriage

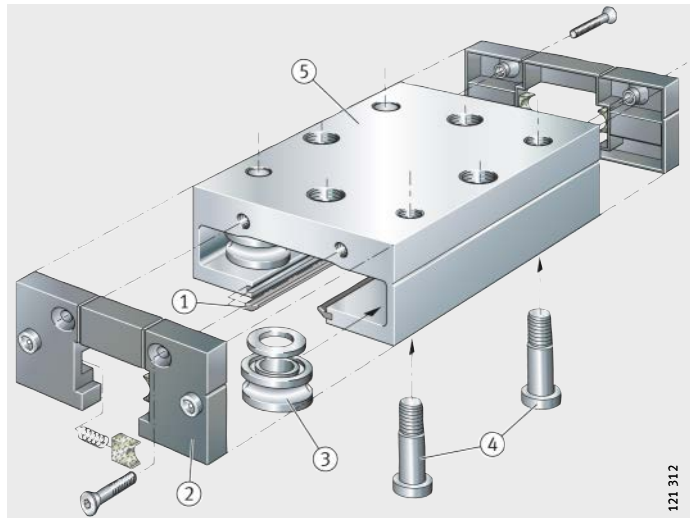

121 312

<b>Preload and clearance</b>	The carriages run clearance-free on all INA guideways, see page 42, and can be combined with all guideways of the relevant size, but not with the curved guideway elements LFSR. Due to the highly accurate guideways, it is not necessary to set the clearance.
<b>Sealing and lubrication</b>	<p>The track rollers have gap seals on both sides, are greased for life and are therefore maintenance-free.</p> <p>For lubrication of the raceways, the lubrication and wiper units have oil-soaked felt inserts that can be replenished with oil via lubrication nipples. In combination with the sealing strips (gap seals), these units protect the compact carriage on all sides against contamination.</p>
<b>Corrosion-resistant design</b>	All steel parts, the inner and outer rings of the track rollers and the bolts, washers and nuts are made from corrosion-resistant steel. The rolling elements are protected against corrosion by the grease. Corrosion-resistant designs have the suffix RB.
<b>Further information</b>	<p>Further information is given on the following pages:</p> <ul style="list-style-type: none"> <li>■ dimension table, see page 58</li> <li>■ track rollers, see page 68</li> <li>■ guideways, see page 76</li> <li>■ accessories, see page 106.</li> </ul>



## Track roller guidance systems

### Track roller guidance system with open carriage

The robust, open carriage LFL..-SF is suitable where high performance linear guidance systems of a simple construction are required.

A carriage comprises a carriage plate made from anodised aluminium, four screws and four track rollers, *Figure 3*. The track rollers are already fitted.

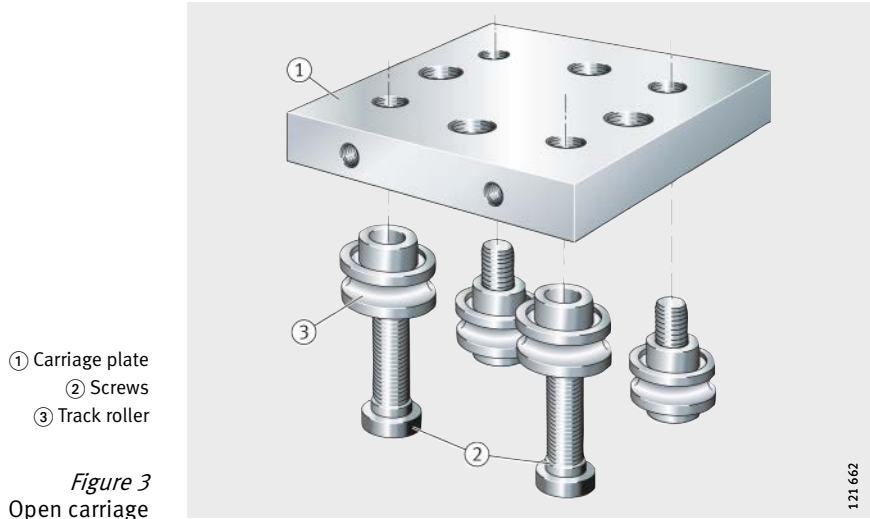

<b>Preload and clearance</b>	The carriages run clearance-free on all INA guideways, see page 42, and can be combined with all guideways of the relevant size, but not with the curved guideway elements LFSR. Due to the highly accurate guideways, it is not necessary to set the clearance.
<b>Sealing and lubrication</b>	<p>The track rollers have gap seals on both sides, are greased for life and are therefore maintenance-free.</p> <p>The raceways can be lubricated by means of lubrication and wiper units AB, see page 106. Their oil-soaked felt inserts can be replenished with oil via lubrication nipples. In combination with side plates ABAL, these units seal the end faces and longitudinal sides of the open carriage, see page 107.</p>
<b>Corrosion-resistant design</b>	<p>All steel parts, the inner and outer rings of the track rollers and the screws, washers and nuts are made from corrosion-resistant steel. The rolling elements are protected against corrosion by the grease.</p> <p>Corrosion-resistant designs have the suffix RB.</p>
<b>Further information</b>	<p>Further information is given on the following pages:</p> <ul style="list-style-type: none"> <li>■ dimension table, see page 60</li> <li>■ track rollers, see page 68</li> <li>■ guideways, see page 76</li> <li>■ accessories, see page 106.</li> </ul>

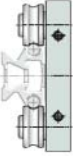

# Track roller guidance systems

## Track roller guidance system with non-locating bearing carriage

Non-locating bearing carriages LFL...-SF are robust, ready-to-fit linear guidance systems that are used exclusively in locating or non-locating bearing applications with two parallel guideway systems. The track rollers can be axially displaced. In this way, it is possible to compensate inaccuracies of  $\pm 1$  mm in relation to the spacing of the guideways.

A carriage comprises a carriage plate made from anodised aluminium, four screws and four non-locating bearing track rollers, *Figure 4*. The track rollers are already fitted.

- ① Carriage plate
- ② Screw
- ③ Non-locating bearing track roller

*Figure 4*  
Non-locating bearing carriage

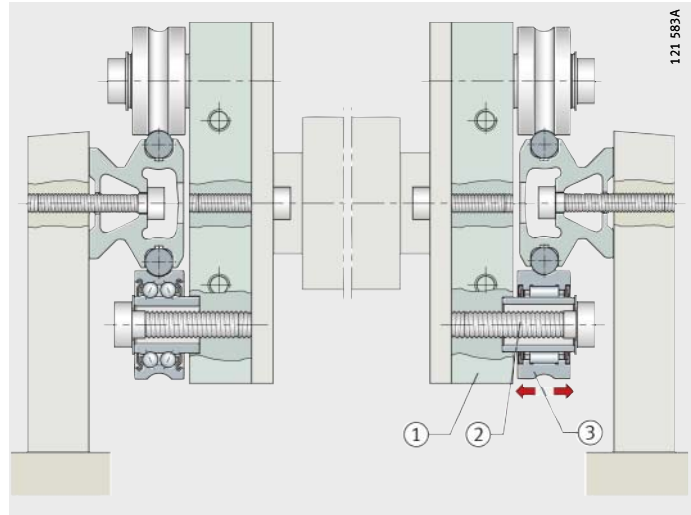

<b>Preload and clearance</b>	The carriages run clearance-free on all INA guideways, see page 42, and can be combined with all guideways of the relevant size, but not with the curved guideway elements LFSR. Due to the highly accurate guideways, it is not necessary to set the clearance.
<b>Sealing and lubrication</b>	The track rollers have gap seals on both sides, are greased for life and are therefore maintenance-free. The contact zone between the raceways and track rollers must be lubricated via the shaft.
<b>Corrosion-resistant design</b>	All steel parts, the inner and outer rings of the track rollers and the screws, washers and nuts are made from corrosion-resistant steel. The rolling elements are protected against corrosion by the grease. Corrosion-resistant designs have the suffix RB (available by agreement only).
	Non-locating bearing carriages must never be used on their own but only ever in combination with locating bearing carriages. The track rollers can support loads in a radial direction only.
<b>Further information</b>	Further information is given on the following pages: <ul style="list-style-type: none"> <li>■ dimension table, see page 62</li> <li>■ track rollers, see page 68</li> <li>■ guideways, see page 76</li> <li>■ accessories, see page 106.</li> </ul>



## Track roller guidance systems

### Track roller guidance system with bogie carriage

Bogie carriages LFDL...-B and LFDL...-SF can be used in combination with curved guideway elements LFSR...-ST to achieve almost any variant of oval and circular track guidance systems. The straight guideway elements are precisely matched to the arc.

The carriages LFDL...-B and LFDL...-SF comprise a steel carriage plate, two aluminium swivel brackets (supported axially and radially by rolling bearings). In the case of LFDL...-B, the preload of the four profiled track rollers can be set by means of two concentric and two eccentric bolts. In the case of LFDL...-SF, the preload is already preset to the optimum value by means of four concentric bolts, *Figure 5*.



LFDL...-SF cannot be mounted on closed curved guideway systems.

- ① Carriage plate
- ② Bracket
- ③ Track roller
- ④ Concentric bolt

*Figure 5*  
Bogie carriage

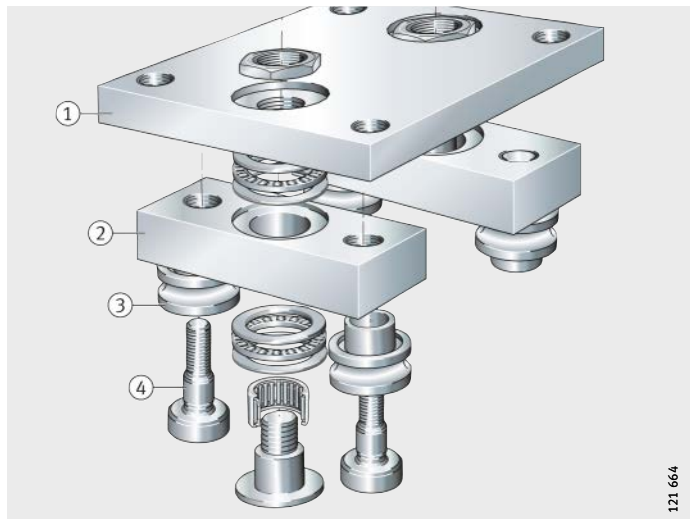



**Sealing and lubrication** The track rollers have gap seals on both sides, are greased for life and are therefore maintenance-free.  
The contact zone between the raceways and track rollers must be lubricated via the shaft.

**Corrosion-resistant design** All steel parts, the inner and outer rings of the track rollers and the bolts, washers and nuts are made from corrosion-resistant steel. The rolling elements are protected against corrosion by the grease.  
Corrosion-resistant designs have the suffix RB (available by agreement only).



The adjustable carriage LFDL..-B must be used in combination with a 360° guideway.

**Further information** Further information is given on the following pages:

- dimension table, see page 64
- track rollers, see page 68
- guideways, see page 76
- accessories, see page 106.



# Track roller guidance system with hollow section carriage

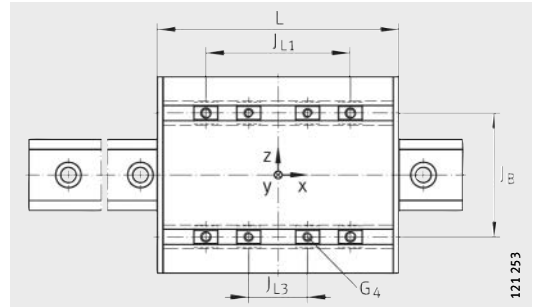

LFCL with LFS (-C, -CE, -CEE, -E, -EE, -NZZ, -M, -F)  
View rotated 90°

**Dimension table** - Dimensions in mm

Carriage <sup>1)</sup>	Mass m  ≈ kg	Track roller <sup>2)</sup>	For shaft diameter	Dimensions			Mounting dimensions		
				H <sub>1</sub>	B	L	J <sub>B</sub>	J <sub>B1</sub>	J <sub>B2</sub>
<b>LFCL25</b>	0,44	<b>LFR50/8-6-2Z</b>	<b>6</b>	30,5	80	110	47	47	69
<b>LFCL42</b>	1	<b>LFR5201-10-2Z</b>	<b>10</b>	38,1	116	150	73	73	98,5
<b>LFCL86<sup>4)</sup></b>	2,2	<b>LFR5301-10-2Z</b>	<b>10</b>	48,4	190	235	124	124	151,5

### Ordering designations

Corrosion-resistant design: LFCL...-RB, LFS...-RB with LFR...-2RSR-RB.  
Guideways without holes: LFS...-OL.

① Threaded slot for screws M3.

- 1) The design of the hollow sections is dependent on the size.
- 2) For ordering of replacement parts, please contact us.
- 3) The guideway LFS...-M can only be combined with carriages with adjustable clearance.  
If SF and LFCL carriages are to be used, please contact us in advance.
- 4) Additional T-slot in the centre of the carriage.

### Basic load ratings<sup>1)</sup>

Carriage	Guideway	Track roller <sup>2)</sup>	Basic load ratings						
			C <sub>y</sub> N	C <sub>0y</sub> N	C <sub>z</sub> N	C <sub>0z</sub> N	M <sub>0x</sub> Nm	M <sub>0y</sub> Nm	M <sub>0z</sub> Nm
<b>LFCL25</b>	<b>LFS25</b>	<b>LFR50/8-6-2Z</b>	4 600	2 400	7 320	4 500	25	120	65
<b>LFCL42</b>	<b>LFS42</b>	<b>LFR5201-10-2Z</b>	10 200	5 480	16 900	10 000	85	425	230
<b>LFCL86</b>	<b>LFS86</b>	<b>LFR5301-10-2Z</b>	17 800	8 850	28 400	15 500	335	1 190	680

1) Basic load ratings in combination with LFS...-RB: see page 18.

2) For ordering of replacement parts, please contact us.

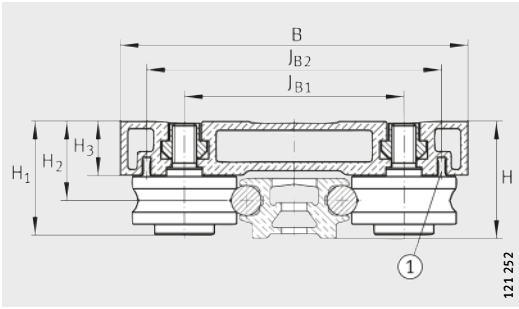

LFCL with LFS (-C, -CE, -CEE, -E, -EE, -N, -NZZ)

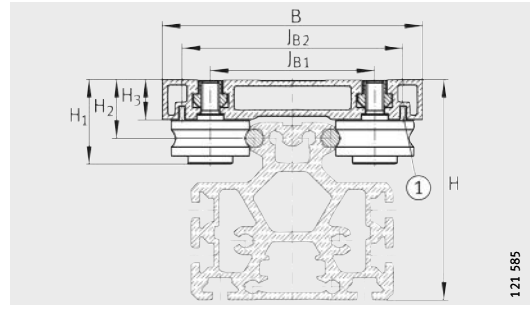

LFCL with LFS..-M<sup>3</sup>)



J <sub>L1</sub>	J <sub>L3</sub>		H <sub>2</sub>	H <sub>3</sub>	G <sub>4</sub>	Maximum screw depth for G <sub>4</sub>	Total height H of carriage and guideway		
	min.	max.					LFS (-C, -CE, -CEE, -E, -EE, -N, -NZZ)	LFS-F	LFS..-M <sup>3</sup> )
58	13	32	+0,3	15,4	M6	10	32,1	—	63,1
85	15	55	26,4	18	M8	12	39	33,9	—
155	18	119	33,9	23,4	M10	14	59	—	—

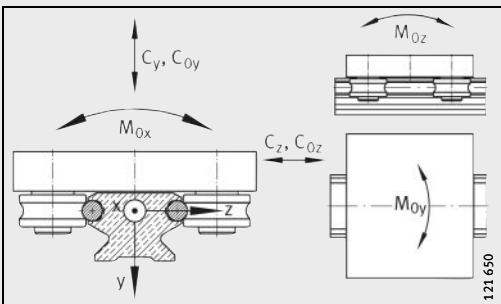

Load directions

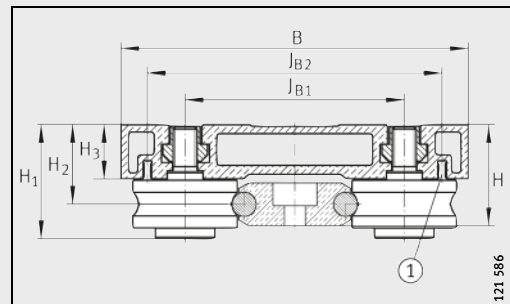

LFCL with LFS..-F

# Track roller guidance system with compact carriage

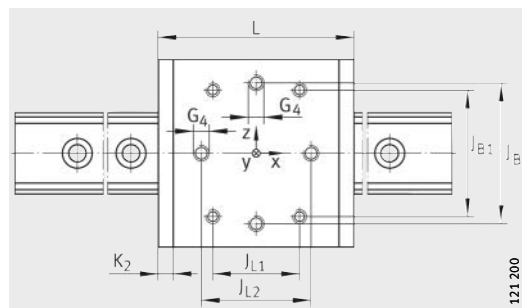

LFKL-SF with LFS (-C, -CE, -CEE, -E, -EE, -NZZ, -M, -F, -FE)  
View rotated 90°

**Dimension table** - Dimensions in mm

Carriage	Mass m  ≈ kg	Track roller <sup>1)</sup>	For shaft diameter	Dimensions			Mounting dimensions		
				H <sub>1</sub>	B	L	J <sub>B</sub>  ±0,2	J <sub>B1</sub>	K <sub>2</sub>
<b>LFKL20-SF</b>	0,2	<b>LFR50/5-4-2Z</b>	<b>4</b>	20,5	56	69	39	34	5
<b>LFKL25-SF</b>	0,3	<b>LFR50/5-6-2Z</b>	<b>6</b>	23,5	65	85	50	40	5
<b>LFKL32-SF</b>	0,7	<b>LFR50/8-6-2Z</b>	<b>6</b>	32	86	112	59	54	7
<b>LFKL52-SF</b>	1,5	<b>LFR5201-10-2Z</b>	<b>10</b>	46,1	130	136	90	83	10
<b>LFKL52-E-SF</b>	2,9	<b>LFR5301-10-2Z</b>	<b>10</b>	53,8	145	186	105	90	10
<b>LFKL52-EE-SF</b>	4,3	<b>LFR5302-10-2Z</b>	<b>10</b>	55	155	205	115	95,2	10

### Ordering designation

Corrosion-resistant design: LFKL..-SF-RB, LFS..-RB with LFR..-2RSR-RB.

Guideways without holes: LFS..-OL.

- 1) For ordering of replacement parts, please contact us.
- 2) Tightening torque for track roller bolts, concentric bolts are supplied tightened to M<sub>A</sub>.
- 3) The guideway LFS..-M can only be combined with carriages with adjustable clearance. If these are to be used, please contact us in advance.

### Basic load ratings<sup>1)</sup>

Carriage	Guideway	Track roller <sup>2)</sup>	Basic load ratings						
			C <sub>y</sub> N	C <sub>0y</sub> N	C <sub>z</sub> N	C <sub>0z</sub> N	M <sub>0x</sub> Nm	M <sub>0y</sub> Nm	M <sub>0z</sub> Nm
<b>LFKL20-SF</b>	<b>LFS20</b>	<b>LFR50/5-4-2Z</b>	1 350	870	2 400	1 700	7	28	15
<b>LFKL25-SF</b>	<b>LFS25</b>	<b>LFR50/5-6-2Z</b>	1 280	820	2 580	1 800	8	40	18
<b>LFKL32-SF</b>	<b>LFS32</b>	<b>LFR50/8-6-2Z</b>	4 100	2 400	6 600	4 200	30	130	70
<b>LFKL52-SF</b>	<b>LFS52</b>	<b>LFR5201-10-2Z</b>	10 000	5 200	16 800	10 000	110	290	150
<b>LFKL52-E-SF</b>	<b>LFS52-E</b>	<b>LFR5301-10-2Z</b>	17 800	8 900	28 400	15 500	180	800	460
<b>LFKL52-EE-SF</b>	<b>LFS52-EE</b>	<b>LFR5302-10-2Z</b>	20 000	10 000	32 400	18 200	215	1 100	620

1) Basic load ratings in combination with LFS..-RB: see page 18.

2) For ordering of replacement parts, please contact us.

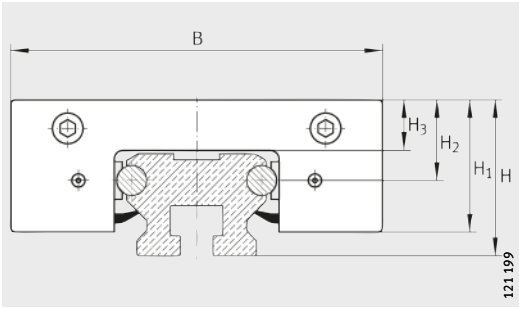

LFKL-SF with LFS (-C, -CE, -CEE, -E, -EE, -NZZ)

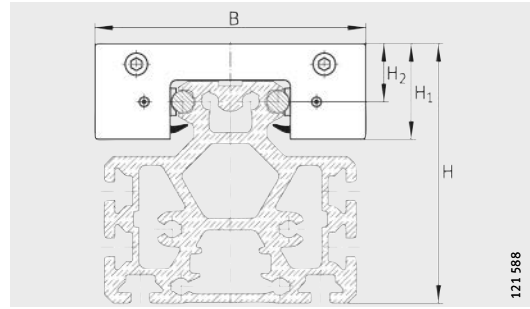

LFKL with LFS...M<sup>3)</sup>



J <sub>L1</sub>	J <sub>L2</sub>	H <sub>2</sub>	H <sub>3</sub>	G <sub>4</sub>	M <sub>A</sub> <sup>2)</sup>		Total height H of carriage and guideway		
					Standard Nm	Corrosion-resistant Nm	LFS (-C, -CE, -CEE, -E, -EE, -NZZ)	LFS-F (-FE)	LFS-M <sup>3)</sup>
	±0,2	+0,3							
34	49	13	8,7	M5	2,5	2,5	22	-	-
45	60	14,4	9	M5	2,5	2,5	25	-	56
60	70	20,5	14	M8	15	12	35,5	25,5	81,5
60	70	29,2	19,4	M10	40	23	54,3	38,2	118,9
105	110	35,3	24	M10	40	23	60,4	44,3	125
120	140	35,3	24	M12	70	39	60,4	44,3	125

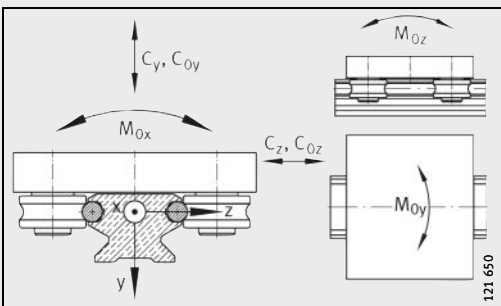

Load directions

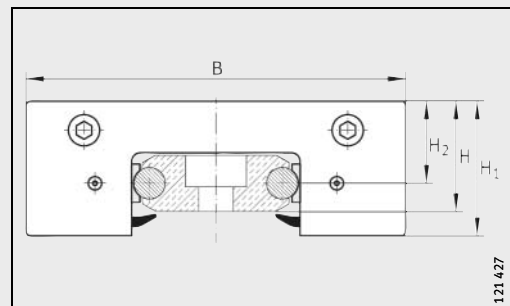

LFKL-SF with LFS..-F (-FE)

# Track roller guidance system with open carriage

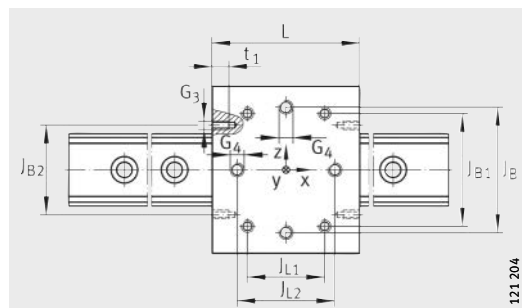

LFL-SF with LFS (-C, -CE, -CEE, -E, -EE, -NZZ, -M, -F, -FE)  
View rotated 90°

**Dimension table** - Dimensions in mm

Carriage	Mass m  ≈ kg	Track roller <sup>1)</sup>	For shaft diameter	Dimensions			Mounting dimensions					
				H <sub>1</sub>	B	L	J <sub>B</sub>	J <sub>B1</sub>	J <sub>B2</sub>	J <sub>L1</sub>	J <sub>L2</sub>	
LFL20-SF	0,16	LFR50/5-4-2Z	4	20,5	55	50	±0,2	40	34	-	24	38
LFL32-SF	0,4	LFRI50/8-6-2Z	6	30	80	90	59	54	56	60	70	
LFL52-SF	1	LFRI5201-10-2Z	10	43,2	120	100	90	83,2	65	60	70	
LFL52-E-SF	1,9	LFRI5301-10-2Z	10	53,8	135	150	105	90	65	105	110	

## Ordering designation

Corrosion-resistant design: LFL...SF-RB, LFS...RB with LFR...2RSR-RB.

Guideways without holes: LFS...OL.

Corrosion-resistant design available by agreement.

- 1) For ordering of replacement parts, please contact us.
- 2) Tightening torque for track roller bolts, concentric bolts are supplied tightened to M<sub>A</sub>.
- 3) The guideway LFS...M can only be combined with carriages with adjustable clearance. If SF and LFCL carriages are to be used, please contact us in advance.

## Basic load ratings<sup>1)</sup>

Carriage	Guideway	Track roller <sup>2)</sup>	Basic load ratings						
			C <sub>y</sub> N	C <sub>0y</sub> N	C <sub>z</sub> N	C <sub>0z</sub> N	M <sub>0x</sub> Nm	M <sub>0y</sub> Nm	M <sub>0z</sub> Nm
LFL20-SF	LFS20	LFR50/5-4-2Z	1 350	870	2 400	1 700	7	20	10
LFL32-SF	LFS32	LFR50/8-6-2Z	4 100	2 400	6 600	4 200	30	130	70
LFL52-SF	LFS52	LFRI5201-10-2Z	10 000	5 200	16 800	10 000	110	290	150
LFL52-E-SF	LFS52-E	LFRI5301-10-2Z	17 800	8 900	28 400	15 500	180	800	460

<sup>1)</sup> Basic load ratings in combination with LFS...RB: see page 18.

<sup>2)</sup> For ordering of replacement parts, please contact us.

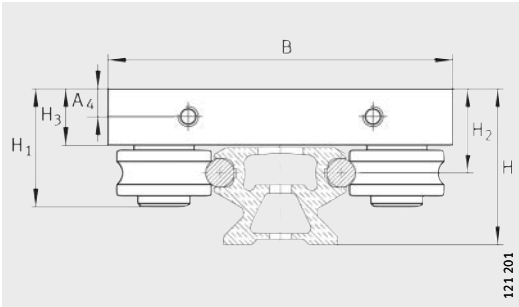

LFL-SF with LFS (-C, -CE, -CEE, -E, -EE, -NZZ)

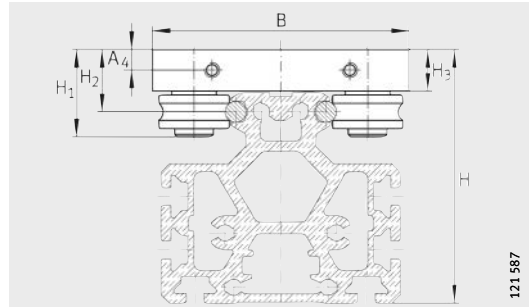

LFL with LFS..-M<sup>3</sup>)



t <sub>1</sub>	H <sub>2</sub>	H <sub>3</sub>	A <sub>4</sub>	G <sub>3</sub>	G <sub>4</sub>	M <sub>A</sub> <sup>2)</sup>		Total height H of carriage and guideway		
						Standard Nm	Corrosion-resistant Nm	LFS (-C, -CE, -CEE, -E, -EE, -NZZ)	LFS-F (-FE)	LFS-M <sup>3)</sup>
-	+0,3	9	-	-	M5	2,5	2,5	22	-	-
7	20,5	14	7	M6	M8	15	12	35,5	25,5	81,5
12	29,2	19,5	9,75	M6	M10	40	23	54,3	38,2	118,9
12	35,3	24	12	M6	M10	40	23	60,4	44,3	125

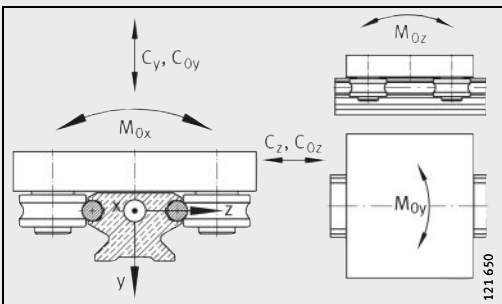

Load directions

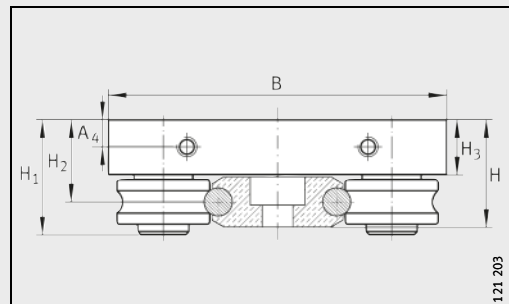

LFL-SF with LFS..-F (-FE)

# Track roller guidance system with non-locating bearing carriage

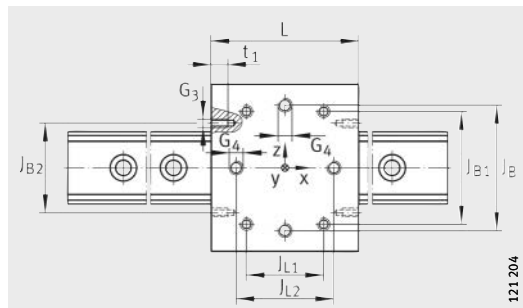

LFL with LFS (-C, -CE, -CEE, -E, -EE, -NZZ, -M, -F, -FE)  
View rotated 90°

**Dimension table** - Dimensions in mm

Carriage	Mass m ≈ kg	For shaft diameter	Dimensions			Mounting dimensions			
			H <sub>1</sub>	B	L	J <sub>B</sub> ±0,2	J <sub>B1</sub>	J <sub>B2</sub>	J <sub>L1</sub>
<b>LFL32-SF</b>	0,4	<b>6</b>	32,5	80	90	59	54	56	60
<b>LFL52-SF</b>	1	<b>10</b>	45	120	100	90	83	65	60

### Ordering designation

Guideways without holes: LFS..-OL.

Corrosion-resistant design available by agreement.

- 1) LFL32-SF: ±0,5 axial displacement capacity.
- 2) LFL52-SF: ±1 axial displacement capacity.

### Basic load ratings<sup>1)</sup>

Carriage	Guideway	Track roller <sup>2)</sup>	Basic load ratings		
			C <sub>z</sub> N	C <sub>0z</sub> N	M <sub>0y</sub> Nm
<b>LFL32-SF</b>	<b>LFS32</b>	<b>LFR22/8-6-2RSR-RNA + IR.LFL32</b>	9 000	8 000	250
<b>LFL52-SF</b>	<b>LFS52</b>	<b>LFR2202-10-2RSR-RNA + IR.LFL52</b>	17 000	19 000	550

1) Basic load ratings in combination with LFS..-RB: see page 18.

2) For ordering of replacement parts, please contact us.



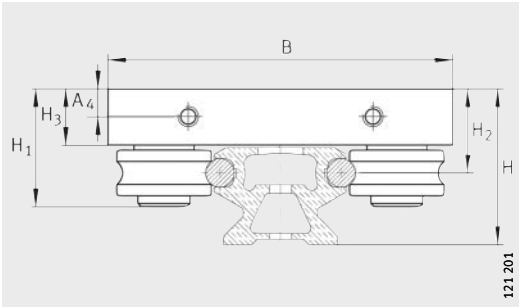

LFL with LFS (-C, -CE, -CEE, -E, -EE, -NZZ)



							Total height H of carriage and guideway	
$l_{L2}$	$t_1$	$H_2$	$H_3$	$A_4$	$G_3$	$G_4$	LFS (-C, -CE, -CEE, -E, -EE, -NZZ)	LFS-F (-FE)
$\pm 0,2$								
70	7	20,5 <sup>1)</sup>	13,75	7	M6	M8	35,5 <sup>1)</sup>	25,5 <sup>1)</sup>
70	12	29,2 <sup>2)</sup>	19,5	9,75	M6	M10	54,3 <sup>2)</sup>	38,2 <sup>2)</sup>

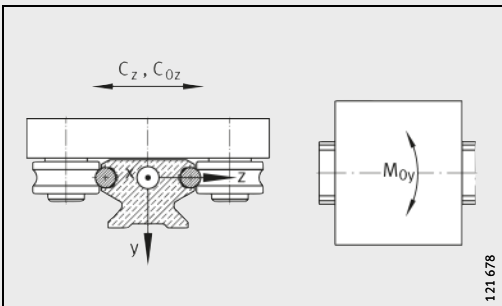

Load directions

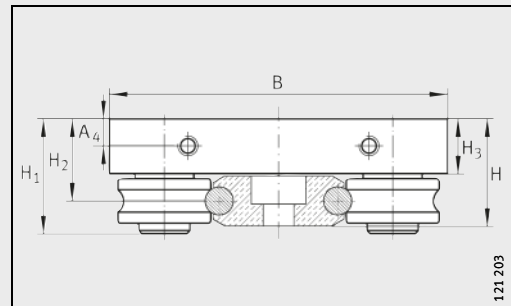

LFL with LFS..-F (-FE)

# Track roller guidance system with bogie carriage

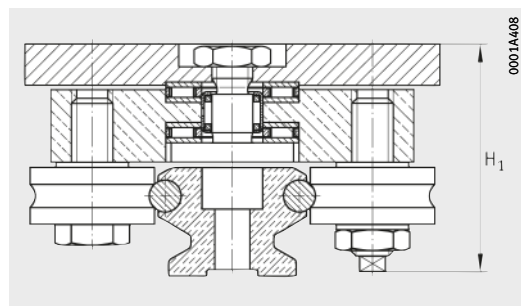

LFDL...-B with LFS (-C, -CE, -CEE, -E, -EE, -NZZ)

**Dimension table** - Dimensions in mm

Carriage <sup>1)</sup>	Mass m ≈ kg	Track roller <sup>2)</sup>	For shaft diameter	Dimensions			Mounting dimensions	
				H <sub>1</sub>	B	L	J <sub>B</sub>	J <sub>B1</sub>
<b>LFDL32-B</b>	1	<b>LFR50/8-6-2Z</b>	<b>6</b>	43	80	100	60	54
<b>LFDL32-SF</b>				37				
<b>LFDL52-B</b>	2,5	<b>LFR5201-10-2Z</b>	<b>10</b>	65,1	120	150	90	83
<b>LFDL52-SF</b>				55				

Corrosion-resistant design available by agreement.

- 1) In order to protect the raceways, the carriages can also be fitted with the lubrication and wiper unit AB (special accessory). Please contact us.
- 2) For ordering of replacement parts, please contact us.
- 3) Tightening torque for track roller bolts, concentric bolts are supplied tightened to M<sub>A</sub>.

**Basic load ratings<sup>1)</sup>**

Carriage	Guideway	Track roller <sup>2)</sup>	Basic load ratings						
			C <sub>y</sub> N	C <sub>0y</sub> N	C <sub>z</sub> N	C <sub>0z</sub> N	M <sub>0x</sub> Nm	M <sub>0y</sub> Nm	M <sub>0z</sub> Nm
<b>LFDL32-B</b>	<b>LFS32</b>	<b>LFR50/8-6-2Z</b>	4 100	2 400	6 600	4 200	30	130	70
<b>LFDL32-SF</b>	<b>LFS32</b>	<b>LFR50/8-6-2Z</b>							
<b>LFDL52-B</b>	<b>LFS52</b>	<b>LFR5201-10-2Z</b>	10 000	5 200	16 800	10 000	110	380	200
<b>LFDL52-B-SF</b>	<b>LFS52</b>	<b>LFR5201-10-2Z</b>							

- 1) Basic load ratings in combination with LFS...-RB: see page 18.
- 2) For ordering of replacement parts, please contact us.

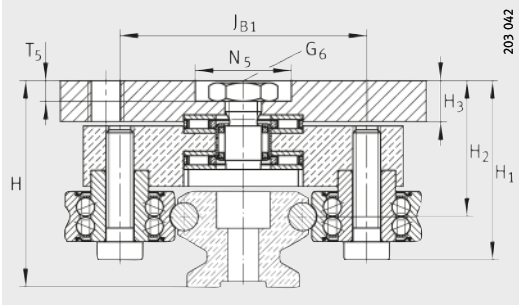

LFDL-SF with LFS (-C, -CE, -CEE, -E, -EE, -NZZ)

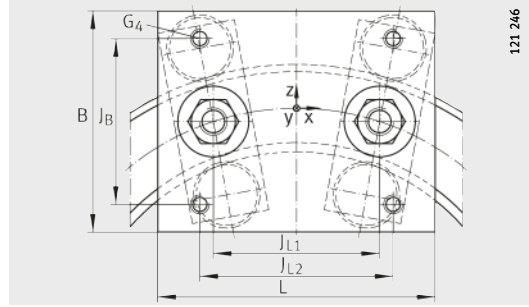

Top view



$J_{L1}$	$J_{L2}$	$H_2$ +0,3	$H_3$	$T_5$	$G_4$	$N_5$	$G_6$	$M_A^{(3)}$ Standard Nm	Total height H of carriage and guideway LFS (-C, -CE, -CEE, -E, -EE, -NZZ)
60	70	29,2	9	5	M8	21	M8	15	44,2
76	90	41	11	6	M10	26	M10	40	66,1

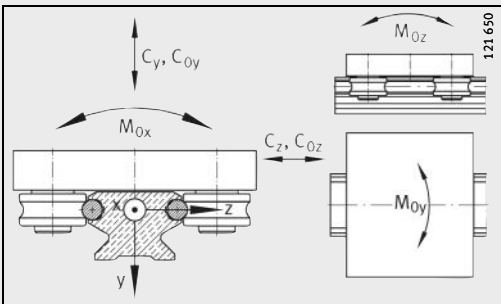

Load directions

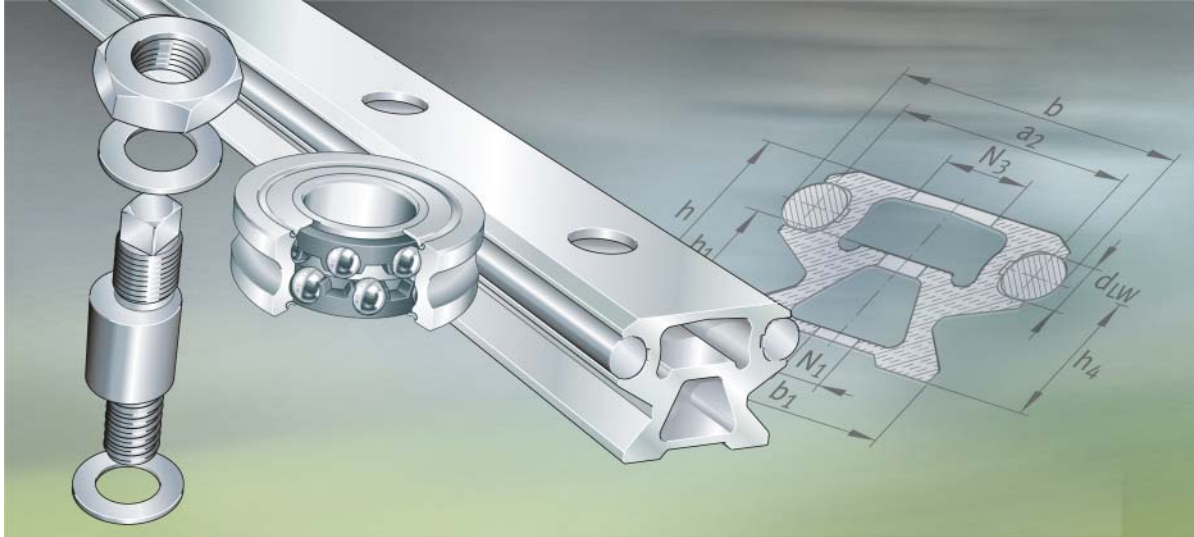

Track rollers  
Bolts  
Guideways

# Track rollers, bolts, guideways

	Page
<b>Product overview</b> Track rollers .....	68
<b>Features</b> .....	69
Possible combinations of track rollers and guideways .....	71
<b>Design and safety guidelines</b> Adjacent construction for non-locating bearing track rollers.....	72
<b>Product overview</b> Bolts .....	73
<b>Features</b> .....	74
<b>Product overview</b> Guideways .....	76
<b>Features</b> .....	78
<b>Design and safety guidelines</b> Hole patterns of guideways.....	80
<b>Dimension tables</b> Locating bearing track rollers .....	84
Bolts .....	88
Non-locating bearing track rollers .....	90
Possible combinations of track rollers and bolts .....	91
Guideways .....	94
Closed oval tracks with guideway connectors VBS .....	102



# Product overview Track rollers

## Locating bearing track roller

LFR

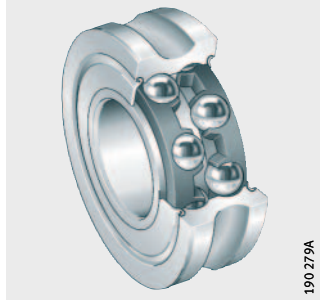

LFRI

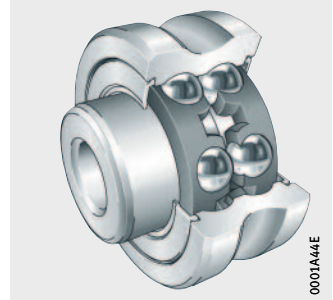

## Non-locating bearing track roller

LFR..-2RSR-NA

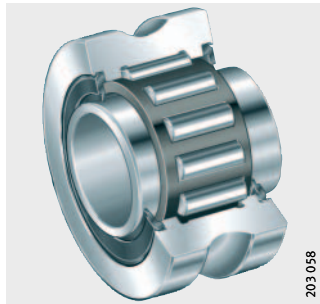

LFR..-2RSR-RNA

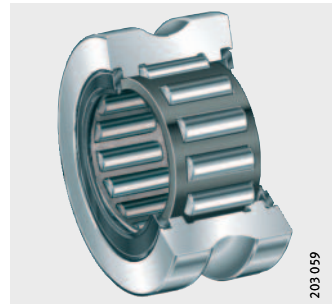

# Track rollers

## Features

Track rollers LFR are double row angular contact ball bearings comprising an outer ring with a gothic arch profile, an inner ring and two ball and cage assemblies with plastic cages. The inner ring and outer ring are made from rolling bearing steel 100Cr6.

The special outer ring gives two point contact in the contact zone with the raceway, *Figure 1*. The contact angle  $\alpha$  is a maximum of  $30^\circ$ .

The bearings can support axial forces from both directions as well as radial forces.

$\alpha = 30^\circ$   
① Gothic arch raceway groove

*Figure 1*  
Gothic arch, two point contact, contact angle

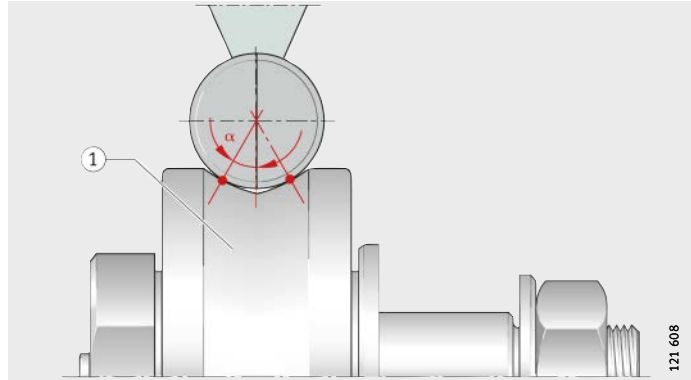

## Track roller with extended inner ring

Track rollers LFRI are double row angular contact ball bearings. They differ from track rollers LFR in that they have an extended inner ring. This allows exact positioning in the adjacent construction.

The inner ring is mounted by means of a standard screw (for example ISO 4762) in a fit hole (preferably grade F6). The fixing screw is not included in the scope of delivery. The operating clearance of track rollers with an extended inner ring cannot be set by means of eccentric bolts.

*Figure 2*  
Track roller LFRI with fixing screw

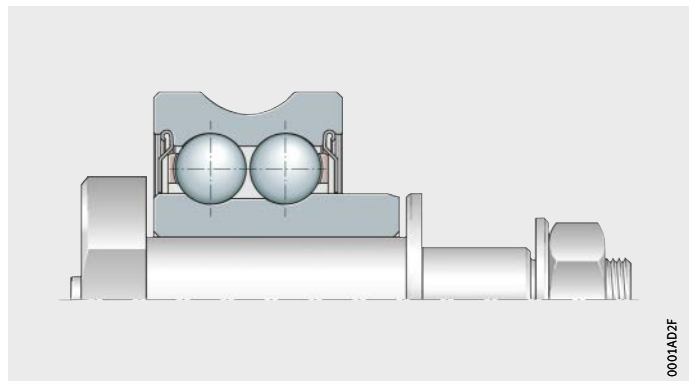

# Track rollers

## Sealing and lubrication

Gap seals on both sides protect the rolling element system against contamination. Bearings with this seal type have the suffix 2Z.

The track rollers are also available on request with contact seals on both sides, suffix 2RS and 2RSR.

The track rollers are greased for life and are therefore maintenance-free. From outside diameter  $\geq 52$  mm, the inner ring has a lubrication bore.

## Seal types

Seal types and their specific features: see table.

### Specific features

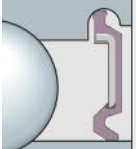
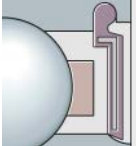
2Z seal	
	Gap seal: <ul style="list-style-type: none"><li>■ not radially preloaded</li><li>■ low friction</li><li>■ to be used with low levels of contamination</li></ul>
2RSR seal	
	Contact seal: <ul style="list-style-type: none"><li>■ radially preloaded</li><li>■ to be used with higher requirements for sealing action and under heavy contamination</li></ul>
2RS seal	
	Contact seal: <ul style="list-style-type: none"><li>■ axially preloaded</li><li>■ to be used with higher requirements for sealing action and under heavy contamination</li></ul>

## Corrosion-resistant design

The inner ring and outer ring are made from corrosion-resistant steel. The rolling elements are protected against corrosion by the grease.

Corrosion-resistant designs have contact seals and the suffix 2RS-RB or 2RSR-RB.

## Accuracy and internal clearance

The dimensional and geometrical accuracies correspond to tolerance class PN to DIN 620.

The radial internal bearing clearance corresponds approximately to internal clearance group Group N in accordance with ISO 5753-1; internal clearance classes: see Catalogue HR 1, Rolling Bearings.

## Further information

Further information is given on the following pages:

- dimension tables, see page 90 and page 91
- bolts, see page 73
- guideways, see page 76
- accessories, see page 106.



## Possible combinations of track rollers and guideways

The tables show the possible combinations of track rollers with the guideways LFS and shaft and support rail unit TS.

### Combinations with guideways LFS

Width and shaft diameter <sup>1)</sup>		Track roller LFR					
LFS	d <sub>LW</sub>	50/5-4	50/5-6	50/8-6	5201-10	5301-10	5302-10
20	4	●	–	–	–	–	–
25	6	–	●	●	–	–	–
32	6	–	–	●	–	–	–
42	10	–	–	–	●	●	●
52	10	–	–	–	●	●	●
86	10	–	–	–	●	●	●
120	10	–	–	–	●	●	●

● available size

<sup>1)</sup> Width b and shaft diameter d<sub>LW</sub>: see dimension tables for guideways.

### Combinations with guideways LFS (continued)

Width and shaft diameter <sup>1)</sup>		Track roller LFR1	
LFS	d <sub>LW</sub>	50/8-6	5201
20	4	–	–
25	6	●	–
32	6	●	–
42	10	–	●
52	10	–	●
86	10	–	●
120	10	–	●

● available size

<sup>1)</sup> Width b and shaft diameter d<sub>LW</sub>: see dimension tables for guideways.



### Combinations with shaft and support rail units TS<sup>1)</sup>

Shaft diameter d <sub>LW</sub> <sup>1)</sup>	Track roller LFR						
	5201-12	5204-16	5206-20	5206-25	5207-30	5208-40	5308-50
12	●	–	–	–	–	–	–
16	–	●	–	–	–	–	–
20	–	–	●	–	–	–	–
25	–	–	–	●	–	–	–
30	–	–	–	–	●	–	–
40	–	–	–	–	–	●	–
50	–	–	–	–	–	–	●

● available size

<sup>1)</sup> Shaft and support rail units TS and shaft diameter d<sub>LW</sub>: see Catalogue WF 1, Shaft Guidance Systems.



# Track rollers

## Design and safety guidelines Adjacent construction for non-locating bearing track rollers

For non-locating bearing track rollers without an inner ring, the rolling element raceway on the shaft must be hardened and ground. The surface hardness must be 670 HV + 170 HV. The hardening depth CHD or SHD must be sufficiently large.

Design of the shaft: see table.

### Tolerances and surface data for the shaft raceway

Diameter tolerance of shafts		Roughness	Roundness	Parallelism
without inner ring	with inner ring			
		max.	max.	max.
k5	g6 (under point load)	Ra 0,4 (Rz 2)	25% of diameter tolerance	50% of diameter tolerance

# Product overview Bolts

## Concentric

LFZ

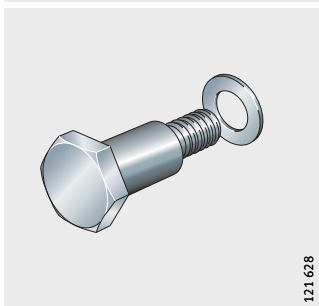

LFZ..-A1

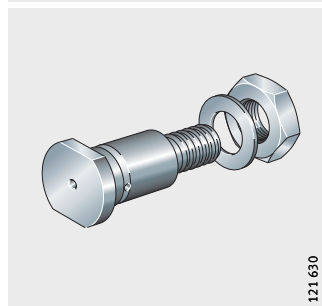

## Eccentric

LFE

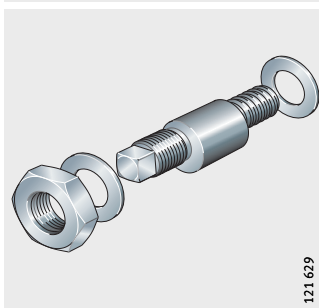

LFE..-A1

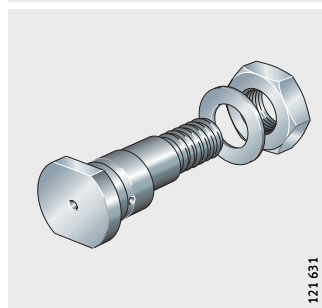

# Bolts

## Features

The bolts, which are made from high strength screw steel, are available with a concentric and eccentric collar; designation LFZ or LFE. Depending on their intended purpose, they are supplied with a washer, nut, drive fit lubrication nipple and sealing cap, see table. The eccentric designs LFE and LFE..-A1 allow the track roller guidance systems to be set clearance-free.

## Delivered condition

Designation and suffix	Scope of delivery	Design
LFZ	Concentric bolt with washer	Standard
LFE	Eccentric bolt with washer and nut	Standard
LFZ..-A1 LFE..-A1	Concentric or eccentric bolt with washer and nut, drive fit lubrication nipple and sealing cap	Standard
NIP-A2	Drive fit lubrication nipple	Accessory
VD2	Sealing cap	Accessory

## Lubrication

Bolts LFZ..-A1 and LFE..-A1 (from size 20) have a lubrication hole. Track rollers of outside diameter  $\geq 52$  mm can be lubricated via this hole. A lubrication nipple NIP-A2 can be pressed into the hole, *Figure 1*. If the hole will not be used for relubrication, it must be closed off using the sealing cap VD2.

- ① Drive fit lubrication nipple NIP-A2
- ② Sealing cap VD2

*Figure 1*  
Drive fit lubrication nipple and sealing cap

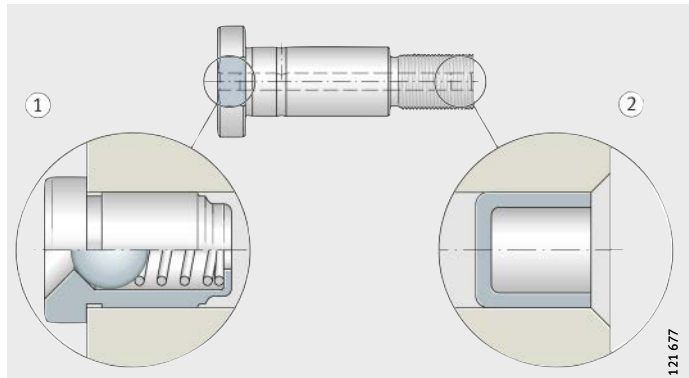

### **Corrosion-resistant design**

In this case, the bolts, washers and nuts are made from corrosion-resistant steel. These designs have the suffix RB.

### **Further information**

Further information is given on the following pages:

- dimension tables, see page 84
- track rollers, see page 68
- guideways, see page 76
- accessories, see page 106.



# Product overview    Guideways

**Solid profile**  
**Hollow section profile**

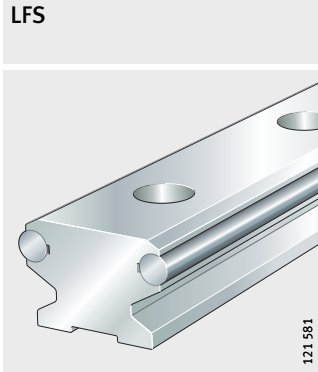

**Flat design**  
**Two raceways or one raceway**

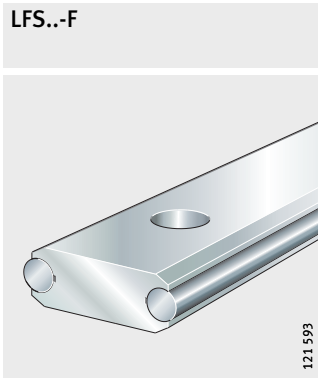

**Profiled section support rail**

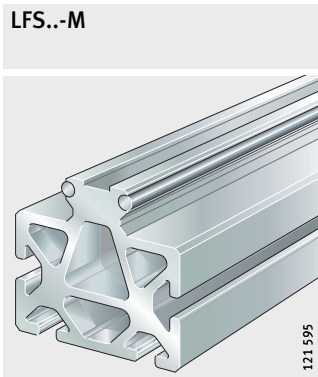

**With slots**  
**For toothed racks or toothed belts**

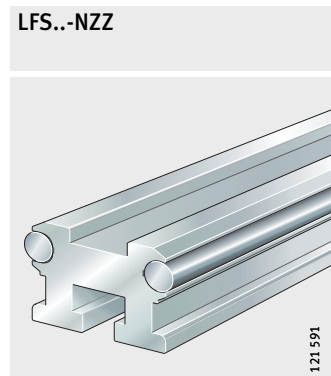
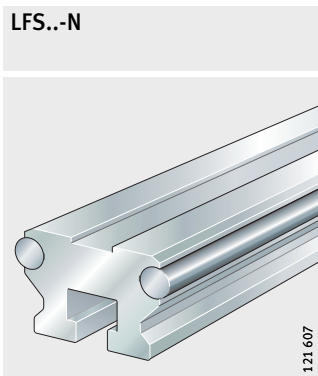

**Wide, flat design**  
For toothed racks or toothed belts

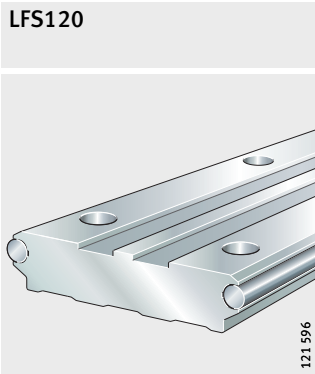

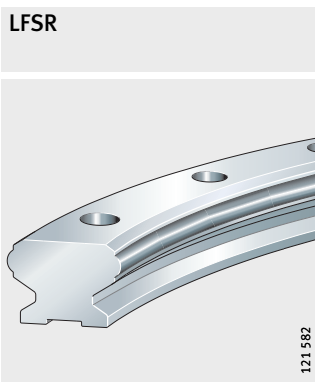

**Curved guideway element**



# Guideways

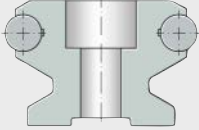
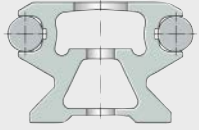

**Features** Guideway designs: see table.

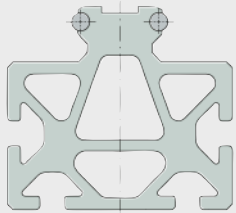
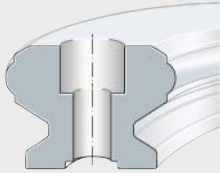
**Designs**

Guideway	Design
<b>LFS</b> 	<ul style="list-style-type: none"> <li>■ With solid profile for location from above through holes</li> </ul>
<b>LFS..-C</b> 	<ul style="list-style-type: none"> <li>■ With hollow section profile (low mass)</li> <li>■ Location from above through holes</li> <li>■ The end faces of the hollow sections are closed off using plastic end covers</li> </ul>
<b>LFS..-F</b> 	<ul style="list-style-type: none"> <li>■ Flat guideway</li> <li>■ Preferably for applications with stationary carriage and moving guideway</li> <li>■ Location from above through holes</li> </ul>
<b>LFS..-M</b> 	<ul style="list-style-type: none"> <li>■ With support rail giving high bending rigidity</li> <li>■ The guideway can be incorporated in modular constructions by means of slots. The slots are designed for nuts to DIN EN ISO 4032 and T-nuts to DIN 508</li> <li>■ The hollow sections are closed off using plastic end covers. Special plastic end covers are available for the slot closing strips</li> </ul>
<b>LFSR</b> 	<ul style="list-style-type: none"> <li>■ Curved guideway element made from steel</li> <li>■ Location from above through holes</li> <li>■ Combinations of curved guideway elements or of curved guideway elements and straight guideways should be treated in the same way as multi-piece guideways and must <b>always be ordered together</b></li> </ul>

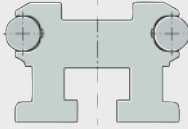
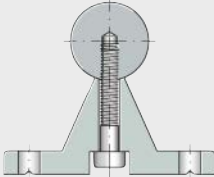

**Designs  
continued**

Guideway	Design
<b>LFS120</b> 	<ul style="list-style-type: none"> <li>Wide, low guideway</li> <li>With recesses for toothed racks or toothed belts</li> <li>Location from above through holes</li> </ul>
<b>LFS..-FH</b> 	<ul style="list-style-type: none"> <li>Flat guideway with only one shaft as raceway</li> <li>Mainly for applications with increased support spacing</li> <li>Location from above through holes</li> </ul>
<b>LFS32-N, LFS..-NZZ</b> 	<ul style="list-style-type: none"> <li>With T-slot for location from below</li> <li>The upper slot in the guideways and the lateral slots are suitable for toothed racks or toothed belts</li> <li>Supplied with special support washers for the fixing screws; the quantity is based on the length of the guideway</li> </ul>
<b>TSN</b> 	<ul style="list-style-type: none"> <li>Composite guideway, aluminium support rail with screw mounted raceway shaft</li> <li>Location from above</li> <li>See Catalogue WF 1, Shaft Guidance Systems</li> </ul>



**Guideways  
without fixing holes**

All LFS guidances with the exception of LFSR are also available without fixing holes; suffix OL.

# Guideways

## Design and safety guidelines Guideway hole patterns

Unless specified otherwise, guideways have a symmetrical hole pattern, *Figure 1*.

Upon request, an asymmetrical hole pattern may be available. In this case,  $a_L \geq a_{L \min}$  and  $a_R \geq a_{R \min}$ .

- ① Symmetrical hole pattern
- ② Asymmetrical hole pattern

*Figure 1*  
Hole patterns of guideways with one row of holes

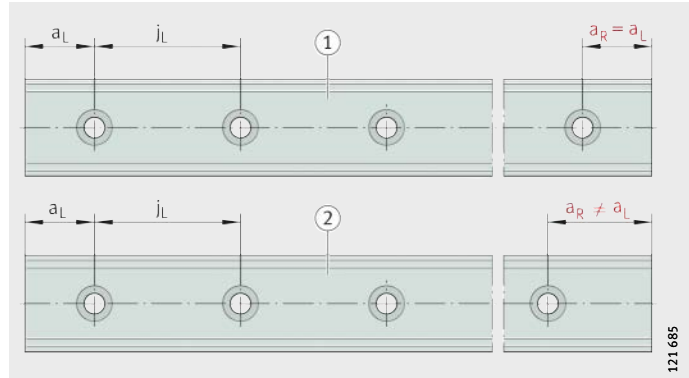

### Hole pitch values

The hole pitch values  $j_L$  are stated in the dimension tables. For high loads, guideways are available with reduced hole pitch values  $j_L$ , *Figure 2*.

These guideways have the suffix E or EE; examples: LFS...-E, LFS...-EE.

*Figure 2*  
Hole spacings  $j_L$

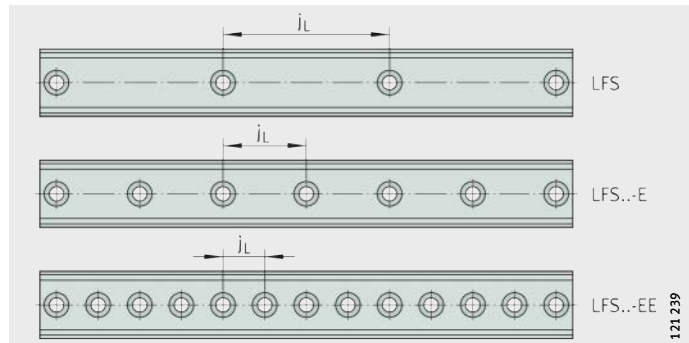

### Maximum number of pitches between holes

The number of pitches between holes is the rounded down whole number equivalent to:

$$n = \frac{l - 2 \cdot a_{L \min}}{j_L}$$

The spacings  $a_L$  and  $a_R$  are generally determined as follows:

$$a_L + a_R = l - n \cdot j_L$$

For guideways with a symmetrical hole pattern:

$$a_L = a_R = \frac{1}{2} \cdot (l - n \cdot j_L)$$

Number of holes:

$$x = n + 1$$

n	–
Maximum possible number of pitches between holes	
l	mm
Guideway length	
$a_{L \min}, a_{R \min}$	mm
Minimum values for $a_L, a_R$ , see dimension tables	
$j_L$	mm
Spacing between holes	
$a_L, a_R$	mm
Spacing between start or end of guideway and nearest hole	
x	–
Number of holes.	



If the minimum values for  $a_L$  and  $a_R$  are not observed, the counter-bores of the holes may be intersected.



# Guideways

**Guideways without holes** All guideways LFS are also available without holes, with the exception of LFSR. These guideways have the suffix OL, for example LFS.-OL.

**Multi-piece guideways** If the guideway length required is greater than  $l_{max}$ , the guideways are assembled from two or more sections matched to each other and marked accordingly. The sections may be of different lengths. The guideway joint is always arranged centrally between the fixing holes, *Figure 3*.

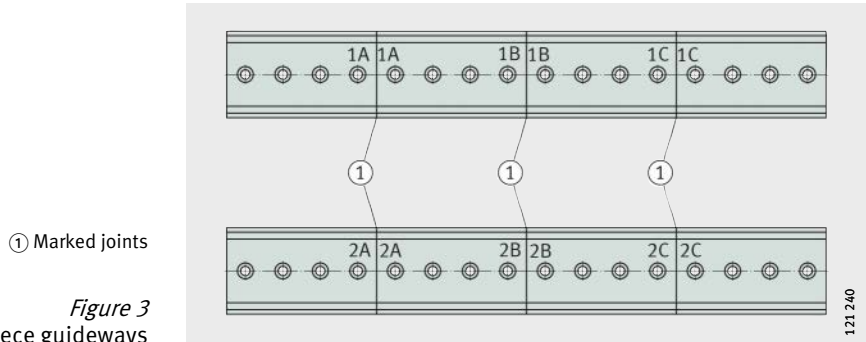

① Marked joints

*Figure 3*  
Multi-piece guideways

**Accuracy of joint position** In order to achieve accuracy of the joint position, additional fixing is recommended for guideways from size 32 if the spacing C7 is larger than the stated limit value, see table and *Figure 4*, page 83.

In these cases, the guideways are supplied with the additional fixing hole already made.

## Spacings for additional hole

Guideway	Spacing between hole and end of guideway	
	C7 Limit value mm	C8 Limit value mm
LFS32 (-C, -F)	30	11
LFS42-C	50	17
LFS52 (-C, -F)	50	17
LFS86-C	50	17
LFS120	50	17

Figure 4  
Additional hole

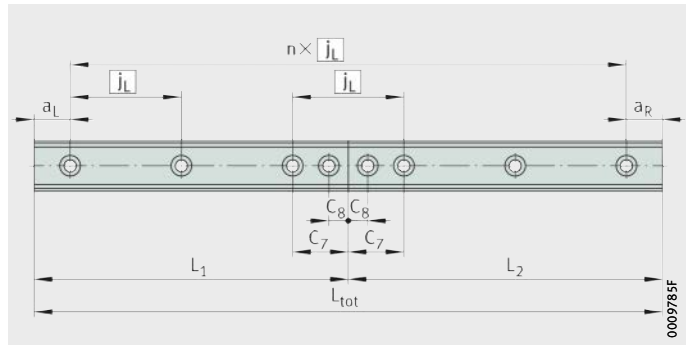

Two guideways LFS can have a deviation relative to each other at the joint position of:

- $\Delta b = \pm 0,01 \text{ mm}$
- $\Delta h_4 = \pm 0,05 \text{ mm}$ , Figure 5.

Figure 5  
Deviation at the joint position  
on guideways assembled  
from sections

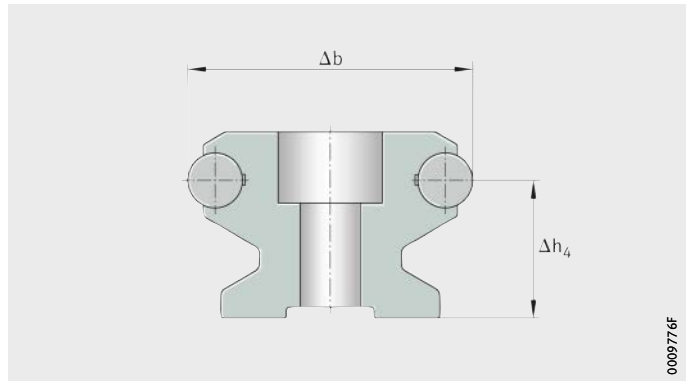

# Locating bearing track rollers

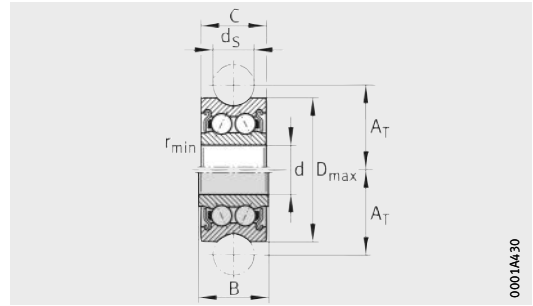

LFR..-2Z

0001A430

**Dimension table** - Dimensions in mm

Designation	Mass m ≈ kg	Dimensions				
		d	D <sub>max</sub>	B	A <sub>T</sub>	C
LFR50/5-4-2Z-HLC <sup>8)</sup>	0,01	5	16	8	9	7
LFR50/5-4-2RS-RB-HLC <sup>8)</sup>						
LFR50/5-6-2Z-HLC <sup>8)</sup>	0,01	5	17	8	10,5	7
LFR50/5-6-2RS-RB-HLC <sup>8)</sup>						
LFR50/8-6-2Z <sup>8)</sup>	0,02	8	24	11	14	11
LFR50/8-6-2RS-RB <sup>8)</sup>						
LFR5201-10-2Z <sup>8)</sup>	0,08	12	35	15,9	20,63	15,9
LFR5201-10-2RS-RB <sup>8)</sup>						
LFR5301-10-2Z <sup>8)</sup>	0,1	12	42	19	24	19
LFR5301-10-2RS-RB <sup>8)</sup>						
LFR5302-10-2Z <sup>8)</sup>	0,17	15	47	19	26,63	19
LFR5302-10-2RS-RB <sup>8)</sup>						
LFR5201-12-2Z <sup>8)</sup>	0,08	12	35	15,9	21,75	15,9
LFR5201-12-2RS-RB <sup>8)</sup>						
LFR5204-16-2Z <sup>9)</sup>	0,23	20	52	22,6	31,5	20,6
LFR5204-16-2RS-RB <sup>9)</sup>						
LFR5206-20-2Z <sup>9)</sup>	0,43	25	72	25,8	41	23,8
LFR5206-20-2RS-RB <sup>7)9)</sup>						
LFR5206-25-2Z <sup>9)</sup>	0,43	25	72	25,8	43,5	23,8
LFR5206-25-2RS-RB <sup>9)</sup>						
LFR5207-30-2Z <sup>9)</sup>	0,66	30	80	29	51	27
LFR5207-30-2RS-RB <sup>7)9)</sup>						
LFR5208-40-2Z <sup>9)</sup>	1,36	40	98	38	62,5	36
LFR5208-40-2RS-RB <sup>7)9)</sup>						
LFR5308-50-2Z <sup>9)</sup>	1,4	40	110	46	72,5	44
LFR5308-50-2Z-RB <sup>7)9)</sup>						

Corrosion-resistant design with suffix ..-RB.

- 1) Rolling contact diameter.
- 2) Effective dynamic load rating as track roller (radial).
- 3) Effective static load rating as track roller (radial).
- 4) Fatigue limit load.
- 5) Permissible dynamic limit load.
- 6) Permissible static limit load.
- 7) Corrosion-resistant design available by agreement.
- 8) Lubricated for life, see page 19.
- 9) Relubrication facility via inner ring, see page 19.

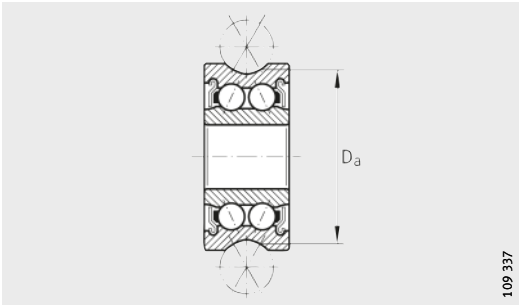

LFR...-2Z

d <sub>s</sub>	D <sub>a</sub> <sup>1)</sup>	r <sub>min</sub>	Load carrying capacity				
			C <sub>rw</sub> <sup>2)</sup> N	C <sub>0rw</sub> <sup>3)</sup> N	C <sub>ur</sub> <sup>4)</sup> N	F <sub>r per</sub> <sup>5)</sup> N	F <sub>0r per</sub> <sup>6)</sup> N
4	14,54	0,2	1 560	850	43	1 700	1 700
6	15,8	0,2	1 630	900	44,5	2 270	1 800
6	22,8	0,3	4 100	2 300	115	2 550	4 600
10	32,25	0,6	8 400	5 000	250	4 750	10 000
10	38,95	0,6	13 200	7 700	370	6 400	15 400
			13 900	8 200	390	19 600	16 400
10	44,25	1	14 500	9 100	455	9 400	18 200
12	33,1	0,6	8 300	5 000	250	4 650	10 000
16	49,14	1	15 300	10 100	520	10 500	20 200
20	64,68	1	23 100	16 400	870	21 100	33 000
25	65,35	1	22 700	16 100	850	18 800	32 000
30	76,02	1	23 100	16 400	1 100	18 500	41 500
40	90,36	1,1	38 500	29 000	1 480	51 000	58 000
50	101,7	1,1	54 000	40 500	2 000	69 000	81 000



# Track rollers

With extended inner ring  
Locating bearing track roller

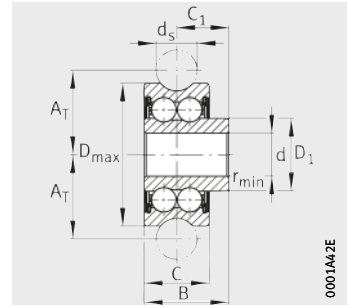

LFRI

**Dimension table** - Dimensions in mm

Designation	Mass m ≈ kg	Dimensions					
		d	D <sub>max</sub>	B	A <sub>T</sub>	C	C <sub>1</sub>
<b>LFRI50/8-6-2Z</b>	0,025	6,1	24	15,1	14	11	9,6
<b>LFRI5201-10-2Z</b>	0,09	10,5	35	20,7	20,63	15,9	12,75

Corrosion-resistant design available by agreement.

- 1) Rolling contact diameter.
- 2) Effective dynamic load rating as track roller (radial).
- 3) Effective static load rating as track roller (radial).
- 4) Fatigue limit load.
- 5) Permissible dynamic limit load.
- 6) Permissible static limit load.



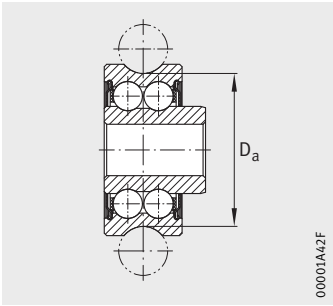

LF1

				Load carrying capacity				
$D_1$	$d_s$	$D_a^{1)}$	$r_{min}$	$C_{rw}^{2)}$	$C_{Orw}^{3)}$	$C_{ur}^{4)}$	$F_{r\ per}^{5)}$	$F_{Or\ per}^{6)}$
j6				N	N	N	N	N
12,6	6	22,8	0,5	4 100	2 300	115	2 550	4 600
17,8	10	32,25	0,5	8 300	5 000	250	4 550	8 300



# Bolts

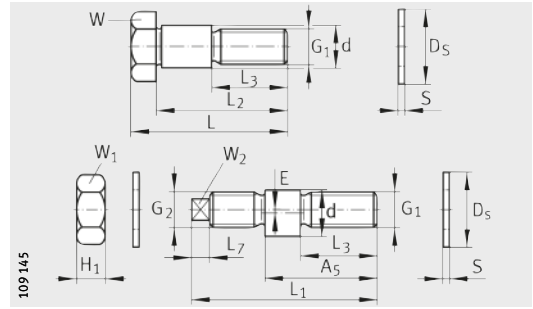

LFZ, LFE

**Dimension table** - Dimensions in mm

Designation	Mass m ≈ kg	Dimensions									
		d	G <sub>1</sub>	G <sub>2</sub>	L	L <sub>2</sub>	L <sub>3</sub>	L <sub>1</sub>	A <sub>5</sub>		
<b>LFZ05</b>	0,01	5	M4	–	19,5	16	9,5	–	–		
<b>LFE05-0,5</b>				M4	–	–	9	20	15		
<b>LFZ08</b>	0,02	8	M8	–	28,3	24,3	15	–	–		
<b>LFE08-1</b>				M8×0,75	–	–	13	32,5	21,6		
<b>LFZ12</b>	0,04	12	M10	–	43	36	22	–	–		
<b>LFE12-1</b>				M10	–	–	19,5	50	33,5		
<b>LFZ12/M12</b>	0,06		M12	–	50,8	43,8	24	–	–		
<b>LFE12-1/M12</b>				M12	–	–		57	41		
<b>LFZ15</b>	0,06	15	M12	–	50,8	43,8	23,8	–	–		
<b>LFE15-1</b>				M12	–	–	24	57	41		
<b>LFZ12×45-A1<sup>2)</sup></b>	0,04	12	M10×1,5	–	50	45	16	–	–		
<b>LFE12×45-A1<sup>2)</sup></b>				–	–	–	–	–	30		
<b>LFZ20×67-A1</b>	0,2	20	M16×1,5	–	75	67	23	–	–		
<b>LFE20×67-A1</b>				–	–	–	–	–	45		
<b>LFZ25×82-A1</b>	0,4	25	M20×1,5	–	92	82	30	–	–		
<b>LFE25×82-A1</b>				–	–	–	–	–	57		
<b>LFZ30×95-A1</b>	0,62	30	M24×1,5	–	107	95	32	–	–		
<b>LFE30×95-A1</b>				–	–	–	–	–	67		
<b>LFZ40×107-A1</b>	1,1	40	M30×1,5	–	117	107	42	–	–		
<b>LFE40×107-A1</b>				–				–	–	–	72
<b>LFZ40×115-A1</b>	1,2			–	–	–		–	–	–	–
<b>LFE40×115-A1</b>				–	–	–		–	–	72	

Corrosion-resistant design available by agreement.

<sup>1)</sup> No washer required.

<sup>2)</sup> Without lubrication hole.

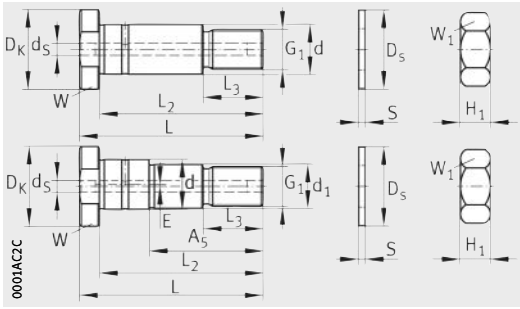

LFZ...A1, LFE...A1

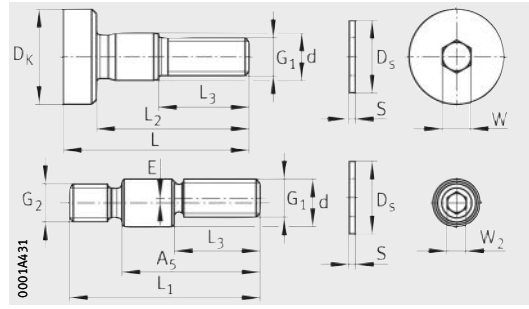

LFZ05 and LFE05-0,5

L <sub>7</sub>	D <sub>s</sub>	E	H <sub>1</sub>	S	D <sub>k</sub>	d <sub>s</sub>	d <sub>1</sub>	Width across flats		
								W	W <sub>1</sub>	W <sub>2</sub>
-	10	-	-	-1)	10	-	-	3	-	-
		0,5	2,9		-	-	-	7	2	
-	14	-	-	1	-	-	-	13	-	-
		1	4					-	13	5
-	21	-	-	1,8	-	-	-	17	-	-
		1	8,4					-	17	6
-	19	-	-	1,8	-	-	-	17	-	-
		1	6,5					-	17	6
-	21	-	-	2	-	-	-	19	-	-
		1	6,5					-	19	6
-	21	-	8	2	20	-	-	17	17	-
-	30	-	13	3	30	5,9	-	27	24	-
		1	-				17	-	-	
-	37	-	16	3	40	5,9	-	36	30	-
		1	-				22	-	-	
-	44	-	19	4	45	5,9	-	41	36	-
		1	-				27	-	-	
-	56	-	24	4	55	5,9	-	46	46	-
		1					36			
		-					-			
		1					36			



# Non-locating bearing track rollers

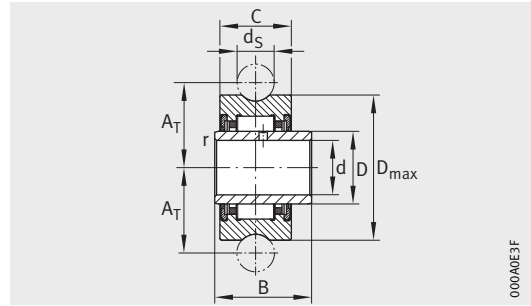

LFR..-2RSR-NA

**Dimension table** - Dimensions in mm

Designation	Inner ring <sup>1)</sup>	Mass m ≈ kg	Dimensions								Load carrying capacity		
			d	D <sub>max</sub>	B <sup>0</sup> <sub>-0,12</sub>	A <sub>T</sub>	C	D	d <sub>s</sub>	r <sub>min</sub>	C <sub>rw</sub> <sup>2)</sup> N	C <sub>0rw</sub> <sup>3)</sup> N	C <sub>urw</sub> <sup>4)</sup> N
<b>LFR22/8-6-2RSR-NA</b>	<b>IR8×12×14</b>	0,032	8	24	14	14	11,8	12	6	0,3	4 000	4 300	630
<b>LFR2202-10-2RSR-NA</b>	<b>IR15×20×16</b>	0,079	15	35	16	20,63	13,8	20	10	0,3	6 500	9 300	1 310
<b>LFR2204-10-2RSR-NA</b>	<b>IR20×25×20</b>	0,17	20	47	20	26,64	17,8	25	10	0,3	13 700	18 600	2 550

Non-locating bearing track rollers are also available without an inner ring: LFR..-2RSR-RNA.

Observe the guidelines relating to the adjacent construction, see page 72.

Corrosion-resistant design available by agreement.

- 1) Lubrication hole in inner ring (diameter) 2 mm.
- 2) Effective dynamic load rating as track roller (radial).
- 3) Effective static load rating as track roller (radial).
- 4) Fatigue limit load.

# Possible combinations of track rollers and bolts

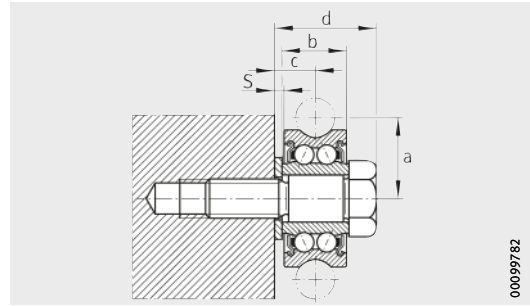

Mounting situation

00099782

Dimension table · Dimensions in mm						
Designation		Dimensions				
Locating bearing track roller	Bolt	a <sup>1)</sup>	b	S	c	d
LFR50/5-4-2Z <sup>2)</sup>	LfZ05	9	8	–	4	11,5
	LfE05-0,5					
LFR50/5-6-2Z	LfZ05	10,5	8	1	5	11,5
	LfE05-0,5					
LFR50/8-6-2Z	LfZ08	14	12	1	6,5	16
	LfE08-1					20,5
LFR5201-10-2Z	LfZ12	20,65	17,7	1,8	9,7	24,7
	LfE12-1					32,3
LFR5301-10-2Z	LfZ12/M12	24	20,8	1,8	11,3	27,8
	LfE12-1/M12					34,8
LFR5302-10-2Z	LfZ15	26,65	21	2	11,5	28
	LfE15-1					35
LFR5201-12-2Z	LfZ12×45-A1	21,75	17,9	2	9,9	22,9
	LfE12×45-A1					
LFR5204-16-2Z	LfZ20×67-A1	31,5	25,6	3	14,3	33,6
	LfE20×67-A1					
LFR5206-20-2Z	LfZ25×82-A1	41	28,8	3	15,9	38,8
	LfE25×82-A1					
LFR5206-25-2Z	LfZ25×82-A1	43,5	28,8	3	15,9	38,8
	LfE25×82-A1					
LFR5207-30-2Z	LfZ30×95-A1	51	33	4	18,5	45
	LfE30×95-A1					
LFR5208-40-2Z	LfZ40×107-A1	62,5	42	4	23	52
	LfE40×107-A1					
LFR5308-50-2Z	LfZ40×115-A1	72,5	50	4	27	60
	LfE40×115-A1					

1) With eccentric bolts, the dimension a varies by ±E in accordance with the table, page 89.

2) No washer required.



# Possible combinations of track rollers and bolts

Flying bearing arrangement with bolt ...-A1

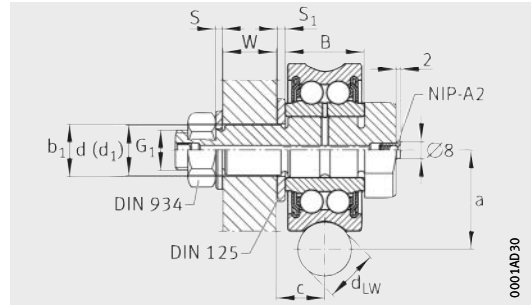

Bolt ...-A1

Dimension table - Dimensions in mm												
Designation		Dimensions										
Locating bearing track roller	Bolt	a	c	d	d <sub>1</sub>	G <sub>1</sub> <sup>1)</sup>	S <sup>2)</sup>	W <sup>3)</sup>	S <sub>1</sub>	b <sub>1</sub>	d <sub>LW</sub>	B
									Washer DIN 125-A			
LFR5201-12-2Z	LFZ12×45-A1	21,75	9,75	12	-	M10×1,5	2	12	2,5	13	12	15,9
	LFE12×45-A1			-	10				2	10,5		
LFR5204-16-2Z	LFZ20×67-A1	31,5	11,3	20	-	M16×1,5	3	20	3	21	20	22,6
	LFE20×67-A1			-	17				3	17		
LFR5206-20-2Z	LFZ25×82-A1	41	12,9	25	-	M20×1,5	3	25	4	27	20	25,8
	LFE25×82-A1			-	22				3	23		
LFR5206-25-2Z	LFZ25×82-A1	43,5	12,9	25	-	M20×1,5	3	25	4	27	25	25,8
	LFE25×82-A1			-	22				3	23		
LFR5207-30-2Z	LFZ30×95-A1	51	14,5	30	-	M24×1,5	4	32	4	31	30	29
	LFE30×95-A1			-	27				4	28		
LFR5208-40-2Z	LFZ40×107-A1	62,5	19	40	-	M30×1,5	4	40	6	41	40	38
	LFE40×107-A1			-	36				5	37		
LFR5308-50-2Z	LFZ40×115-A1	72,5	23	40	-	M30×1,5	4	40	6	41	40	46
	LFE40×115-A1			-	36				5	37		

1) For nuts in accordance with DIN 934, included in the scope of delivery.  
 2) For washers in accordance with DIN 125, included in the scope of delivery.  
 3) Recommended minimum wall thickness.



# Guideways

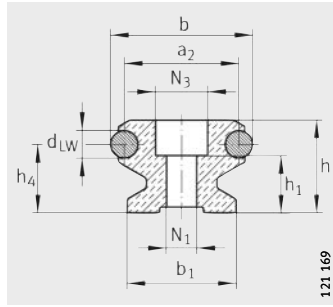

LFS

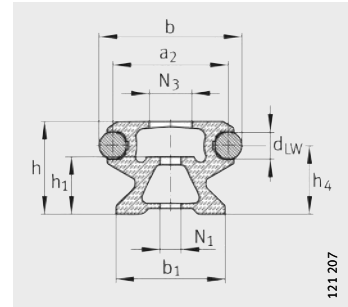

LFS...C

**Dimension table** - Dimensions in mm

Designation	Mass m  ≈ kg	Dimensions			Mounting dimensions						
		b	h	l <sub>max</sub> <sup>1)</sup>	b <sub>1</sub>	a <sub>2</sub>	j <sub>L</sub>	a <sub>L</sub> <sup>2)</sup>		a <sub>R</sub> <sup>2)</sup>	
								min.	max.	min.	max.
LFS20	0,6	20	12,2	2 400	17	16	62,5	9	54	9	54
LFS25	1,1	25	15	2 400	21	19	62,5	10	54	10	54
LFS32	1,6	32	20	6 000	24	26	125	11	116	11	116
LFS32-E							62,5		52		52
LFS32-C <sup>4)</sup>	125						116		116		
LFS32-CE <sup>4)</sup>	62,5						52		52		
LFS32-F	1		10	4 000	-		125		116		116
LFS42-C <sup>4)</sup>	2,2	42	20	6 000	28	32	125	20	113	20	113
LFS42-CE <sup>4)</sup>							62,5		51		51
LFS42-F							125		17		17
LFS52	4,4	52	34	6 000	40	42	250	17	235	17	235
LFS52-E							125		110		110
LFS52-EE	62,5						49		49		
LFS52-C <sup>4)</sup>	250						235		235		
LFS52-CE <sup>4)</sup>	125						110		110		
LFS52-CEE <sup>4)</sup>	62,5						49		49		
LFS52-F	250						235		235		
LFS52-FE	125						110		110		
LFS86-C <sup>4)</sup>	4,4	86	34	6 000	71	76	250	17	235	17	235
LFS86-CE <sup>4)</sup>							125		110		110
LFS120	7,9	120	25	8 000	100	110	250	17	235	17	235
LFS120-E							125		110		110

**Guideways of corrosion-resistant design: LFS...-RB, observe note on page 18.**

Modulus of elasticity for LFS...-C (-CE, -CEE, -E, -EE, -F, -FE): 72 000 N/mm<sup>2</sup>.

Guideways LFS, LFS...-C and LFS...-F available without holes: LFS...-OL (-C-OL, -F-OL).

① Underside marked

1) Maximum length of single-piece guideways; longer guideways are supplied in several sections and are marked accordingly. Observe the length tolerances, see page 30.

2) a<sub>L</sub> and a<sub>R</sub> are dependent on the guideway length l<sub>max</sub>, calculation: see page 80.

3) Under maximum load F<sub>Z</sub> and F<sub>0Z</sub>, support washers to DIN 433 and the maximum tightening torque according to the table, page 29, are required.

4) The design of the hollow sections is dependent on the size.

5) Counterbore depth for screws to DIN 7984.

6) If support washers to DIN 433 are used, screws to DIN 7984 are recommended.



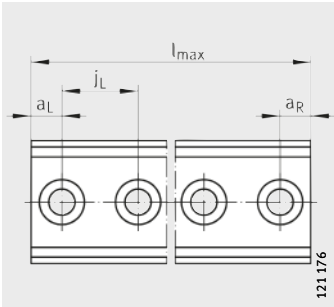

LFS, LFS...-C (-F)  
View rotated 90°

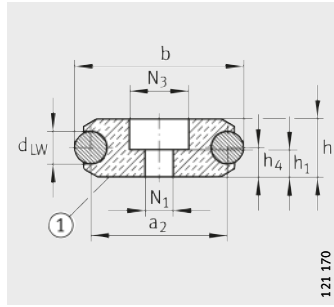

LFS...-F

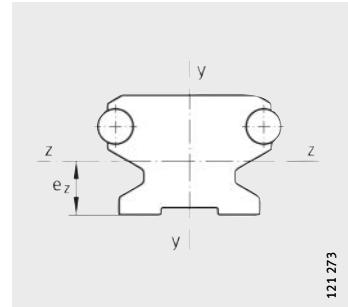

Bending axes

d <sub>LW</sub>	h <sub>4</sub>	h <sub>1</sub>	N <sub>1</sub>	N <sub>3</sub> <sup>3)</sup>	Surface data					
					Cross-sectional area mm <sup>2</sup>	y-y		z-z		
						I <sub>y</sub> mm <sup>4</sup>	W <sub>y</sub> mm <sup>3</sup>	e <sub>z</sub> mm	I <sub>z</sub> mm <sup>4</sup>	W <sub>z</sub> mm <sup>3</sup>
4	9	7,6	4,5	8	165	3 065	362	6,4	2 053	324
6	10,6	8,5	5,5	10	237	6 390	608	7,5	4 510	600
6	15	12	6,5	12	440	20 100	1 440	10,4	14 100	1 360
					261	18 305	1 165	10,1	10 072	995
					5	3,5 <sup>5)</sup>	230	11 300	810	5
10	12,6	12 <sup>6)</sup>	9	15	358	33 929	1 858	10,1	14 052	1 391
	7,5	8 <sup>5)</sup>			370	29 280	1 864	7,5	16 200	2 160
10	25,1	21	11	19	1 170	138 624	5 878	17,8	113 037	6 350
					649	113 821	4 896	17,1	74 878	4 378
					9	8 <sup>5)</sup>	670	84 000	3 610	9
10	25,1	21 <sup>6)</sup>	13	21	1 185	613 720	16 587	17,5	155 160	8 866
10	16,1	12	11	19	2 468	2 330 980	40 751	12,5	9 365	117 074

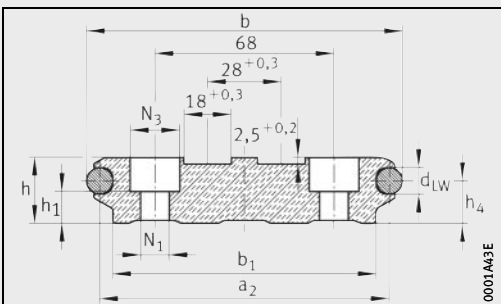

LFS120

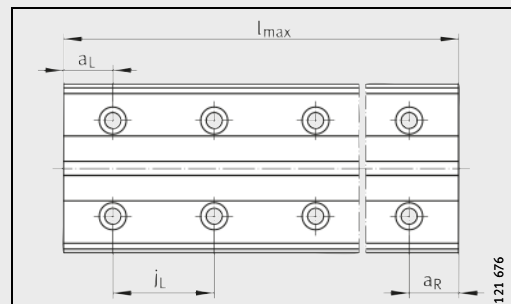

LFS120

# Guideways

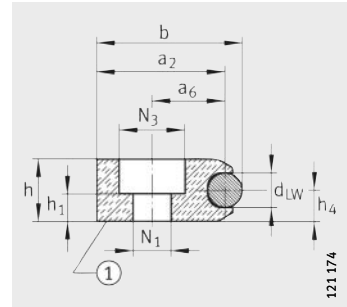

LFS..-FH

**Dimension table** - Dimensions in mm

Designation	Mass m  ≈ kg	Dimensions			Mounting dimensions						
		b	h	l <sub>max</sub> <sup>1)</sup>	a <sub>2</sub>	a <sub>6</sub>	j <sub>L</sub>	a <sub>L</sub> <sup>2)</sup>		a <sub>R</sub> <sup>2)</sup>	
								min.	max.	min.	max.
LFS32-FH	0,8	26	10	4 000	23	13	125	11	116	6	116
LFS32-FHE							62,5		52		52
LFS52-FH	2,3	42	18	6 000	37	21	250	17	235	10	235
LFS52-FHE							125		110		110
LFS52-FHEE							62,5		49		49

**Guideways of corrosion-resistant design: LFS..-RB, observe note on page 18.**

Guideways LFS..-FH available without holes: LFS..-FH-OL.

Modulus of elasticity for LFS..-FH (-FHE, -FHEE): 72 000 N/mm<sup>2</sup>.

① Underside marked

- 1) Maximum length of single-piece guideways; longer guideways are supplied in several sections and are marked accordingly. Observe the length tolerances, see page 30.
- 2) a<sub>L</sub> and a<sub>R</sub> are dependent on the guideway length l<sub>max</sub>, calculation: see page 80.
- 3) For screw to DIN 912-8.8 (DIN EN ISO 4762), under maximum load support washers to DIN 433 (DIN EN ISO 7092) are required.
- 4) Counterbore depth for screws to DIN 7984.

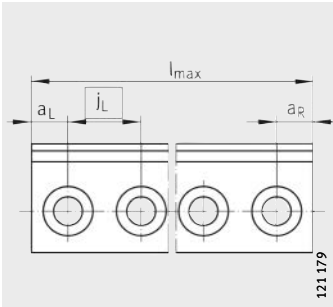

LFS...FH  
View rotated 90°

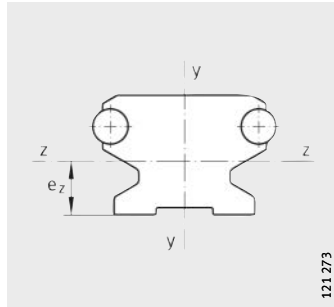

Bending axes

					Surface data					
d <sub>LW</sub>	h <sub>1</sub>	h <sub>4</sub>	N <sub>1</sub> <sup>3)</sup>	N <sub>3</sub>	Cross-sectional area mm <sup>2</sup>	y-y		z-z		
						l <sub>y</sub> mm <sup>4</sup>	W <sub>y</sub> mm <sup>3</sup>	e <sub>z</sub> mm	I <sub>z</sub> mm <sup>4</sup>	W <sub>z</sub> mm <sup>3</sup>
6	3,5	5	6,5	12	216	8 681	790	5	1 897	379
10	8 <sup>4)</sup>	9	11	19	629	66 642	3 765	9	17 798	1 977



# Guideways

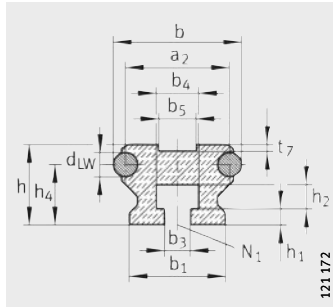

LFS32-N

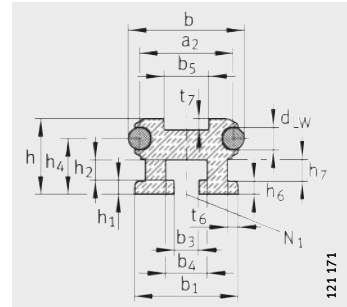

LFS52-NZZ

**Dimension table** - Dimensions in mm

Designation	Mass m  ≈ kg/m	Dimensions			Mounting dimensions												
		b	h	$l_{max}^{1)}$	$b_1$	$a_2$	$b_3^{2)}$	$b_4$	$b_5$	$t_6$	$a_7$	$j_L^{3)}$	$d_{LW}$	$h_1$	$h_2$	$h_5$	$h_4$
LFS25-M <sup>5)</sup>	3,5	25	46	4 000	56	19	-	-	5,2	30	-	-	6	-	22	-	41,6
LFS32-M <sup>5)</sup>	6,4	32	66,5	8 000	75	26	-	-	10,2	43	-	-	6	-	25	-	61
LFS32-N	1,4		20	4 000	24		6,5	10,5	10,5	-	-	125		4	6	-	15
LFS52-M <sup>5)</sup>	11,2	52	98,6	8 000	112	42	18	44	10,2	80	52	-	10	-	25	50	89,7
LFS52-NZZ	3,9		34		46,5		11	18,5	18,5	4,7	-	250		6,4	9	-	25,1

**Guideways of corrosion-resistant design: LFS.-RB, observe note on page 18.**

Modulus of elasticity for LFS.-M (-N, -NZZ, -ZZ): 72 000 N/mm<sup>2</sup>.

① For LFS52-M and LFS32-M; ② For LFS25-M; ③ Detail of slot

- 1) Maximum length of single-piece guideways; longer guideways are supplied in several sections and are marked accordingly. Observe the length tolerances, see page 30.
- 2) For screw to DIN 931 (DIN EN ISO 4014), DIN 933-8.8 (DIN EN ISO 4017), special support washers included in scope of delivery for guideways LFS52-NZZ.
- 3) Recommended screw pitch (hole spacing), see page 80.
- 4) One core hole for non-cutting thread drill or self-tapping screws to DIN 7513.
- 5) The guideway LFS.-M can only be combined with carriages with adjustable clearance. If SF and LFCL carriages are to be used, please contact us in advance.

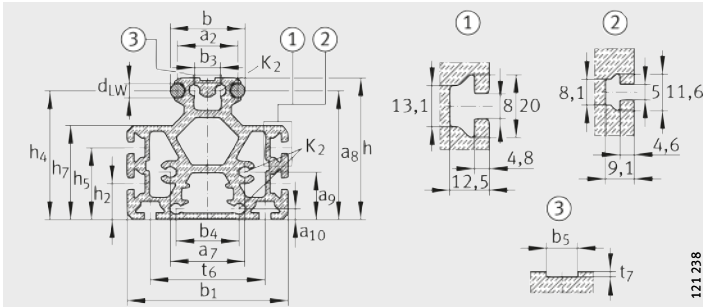

LFS...M

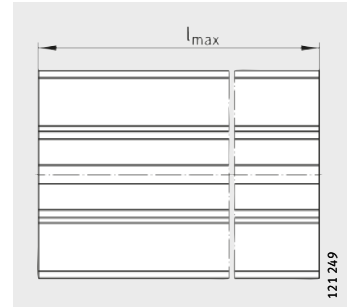

LFS...M  
View rotated 90°

								Surface data					
h <sub>7</sub>	h <sub>6</sub>	t <sub>7</sub>	a <sub>10</sub>	a <sub>9</sub>	a <sub>8</sub>	N <sub>1</sub>	K <sub>2</sub>	Cross-sectional area	y-y		z-z		
									l <sub>y</sub>	W <sub>y</sub>	e <sub>z</sub>	I <sub>z</sub>	W <sub>z</sub>
								mm <sup>2</sup>	mm <sup>4</sup>	mm <sup>3</sup>	mm	mm <sup>4</sup>	mm <sup>3</sup>
31,5	-	1,6	-	-	-	-	4,65	1 156	314 429	11 230	19,4	186 693	9 623
47	-	1,6	-	-	-	-	-	2 206	1 000 234	26 672	36,8	762 105	20 707
-	-	1,6	-	-	-	M6	-	360	19 600	1 400	11,1	12 600	1 135
65,4	-	1,8	7,5	33	89,7	-	7,45	3 691	3 717 250	66 380	42,6	3 014 470	55 462
10	6	5	-	-	-	M10	-	994	170 350	7 327	16,8	82 786	4 927

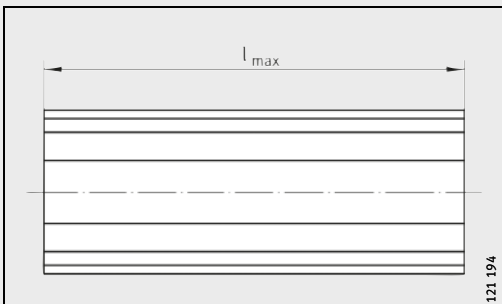

LSF52-NZZ  
View rotated 90°

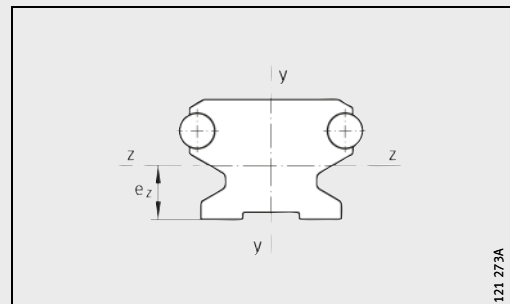

Bending axes

# Guideways

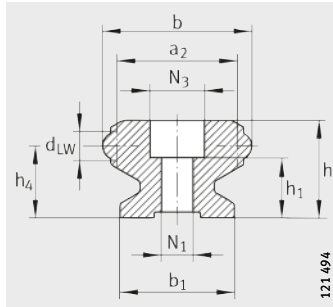

LFSR...-ST

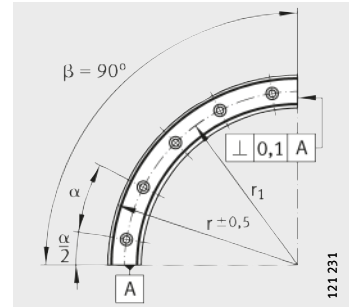

LFSR../90-ST

**Dimension table** - Dimensions in mm

Designation	Mass m ≈ kg	Dimensions					
		b	h	r	$\beta$ °	b <sub>1</sub>	a <sub>2</sub>
LFSR32-100/90-ST	0,5	32	20	100	90	24	26
LFSR32-100/180-ST	1				180		
LFSR32-100/360-ST	2				360		
LFSR32-150/90-ST	0,8			150	90		
LFSR32-150/180-ST	1,6				180		
LFSR32-150/360-ST	3,2				360		
LFSR32-300/90-ST	1,7			300	90		
LFSR32-300/180-ST	3,4				180		
LFSR32-300/360-ST	6,8				360		
LFSR32-500/90-ST	2,9			500	90		
LFSR32-500/180-ST	5,8				180		
LFSR32-500/360-ST	11,6				360		
LFSR52-150/90-ST	2	52	34	150	90	40	42
LFSR52-150/180-ST	4				180		
LFSR52-150/360-ST	8				360		
LFSR52-300/90-ST	4,5			300	90		
LFSR52-300/180-ST	9				180		
LFSR52-300/360-ST	18				360		
LFSR52-500/90-ST	7,8			500	90		
LFSR52-500/180-ST	15,6				180		
LFSR52-500/360-ST	31,2				360		

Attention!

If curved guideway elements are required in combination with straight guideway sections, these must always be ordered together as a unit.

Note the guidelines relating to mounting of curved guideway elements, see page 27.

Corrosion-resistant design available by agreement.

1) For screw to DIN ISO 4762-8.8.

2) Number of holes on the pitch circle  $r_1$ .

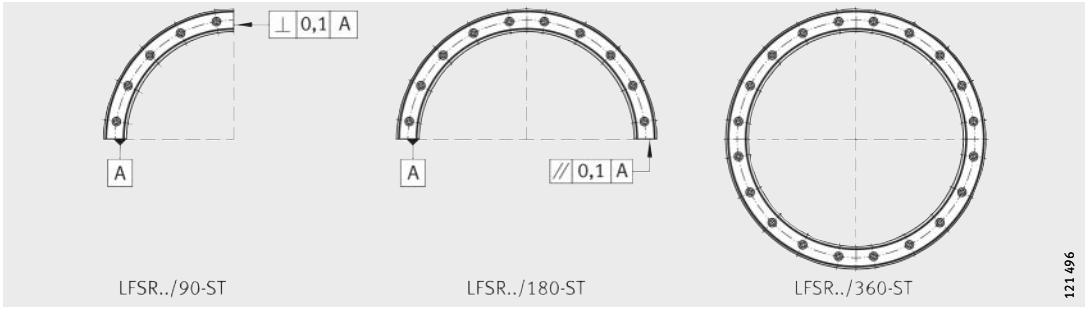

LFSR..-ST

$d_{LW}$	$h_1$	$h_4$	$N_1^{1)}$	$N_3$	$x^{2)}$	$r_1$	$\alpha_o$	$\alpha/2_o$			
6	13,5	15	6,5	12	3	84	30	15			
					6						
					12						
					284	3	22,5	11,25			
						6					
						12					
						4					
						8					
						16					
					484	5	18	9			
						10					
						20					
10	21	25,1	11	19		3			124	30	15
						6					
						12					
					274	4	22,5	11,25			
						8					
						16					
						474			5	18	9
									10		
									20		



# Closed oval tracks with guideway connectors VBS

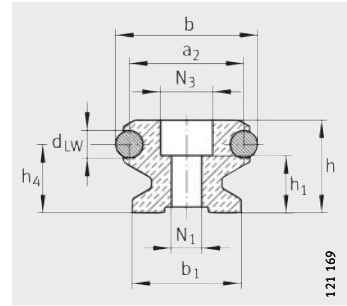

LFS (section A-A)

**Dimension table** - Dimensions in mm

Closed oval tracks		Dimensions				Mounting dimensions	
Designation		b	h	$\beta$ °	$l_{max}^{1)}$	$b_1$	$a_2$
with two 180° arcs	with four 90° arcs						
–	<b>LFS32×...×...-OV-100-VBS</b>	32	20	90	6 000	24	26
<b>LFS32×...-OV-100-VBS</b>	–			180			
–	<b>LFS32×...×...-OV-150-VBS</b>			90			
<b>LFS32×...-OV-150-VBS</b>	–			180			
–	<b>LFS32×...×...-OV-300-VBS</b>			90			
<b>LFS32×...-OV-300-VBS</b>	–			180			
–	<b>LFS32×...×...-OV-500-VBS</b>			90			
<b>LFS32×...-OV-500-VBS</b>	–			180			
–	<b>LFS52×...×...-OV-150-VBS</b>	52	34	90	6 000	40	42
<b>LFS52×...-OV-150-VBS</b>	–			180			
–	<b>LFS52×...×...-OV-300-VBS</b>			90			
<b>LFS52×...-OV-300-VBS</b>	–			180			
–	<b>LFS52×...×...-OV-500-VBS</b>			90			
<b>LFS52×...-OV-500-VBS</b>	–			180			

**Attention!**

If curved guideway elements are required in combination with straight guideway sections, these must always be ordered together as a unit.

Closed oval tracks can only be ordered as a single unit.

A unit consists of two curved guideway elements LFSR with an arc dimension 180° and two straight guideways LFS or a unit of four curved guideways LFSR with an arc dimension 90° and four straight guideways LFS.

Note the guidelines relating to mounting of curved guideway elements, see page 27.

- 1) Maximum length of single-piece guideways.
- 2) For screw to DIN ISO 4762-8.8.
- 3) Number of holes on the pitch circle  $r_1$ .

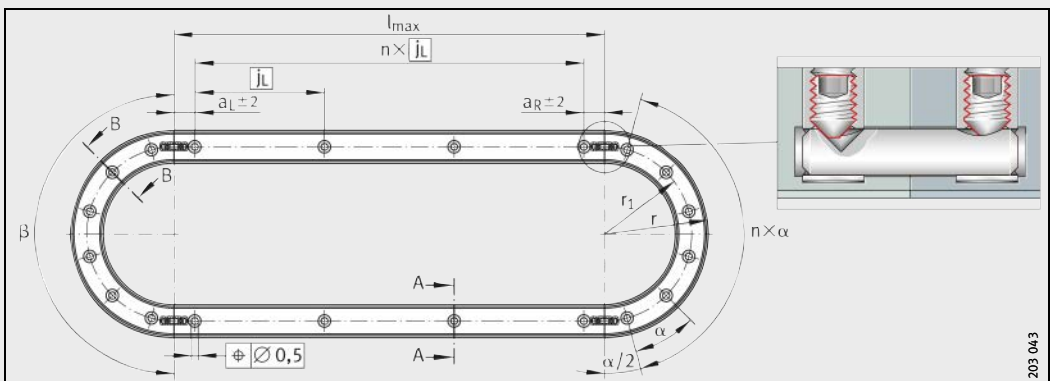

Closed oval track with two 180° arcs



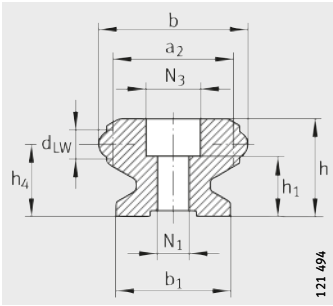

LFSR (section B-B)

$j_L$	$a_L, a_R$		$d_{LW}$	$h_1$	$h_4$	$N_1^{2)}$	$N_3$	$x^{3)}$	$r$	$r_1$	$\alpha$ °					
	min.	max.														
125	36	116	6	12	15	6,5	12	3	100	84	30					
								6								
	30	116						6	12	15	6,5	12	3	150	134	22,5
													6			
													4	300	284	18
													8			
5	500	484	18													
10																
250	49	235	10	21	25	11	19	3	150	124	30					
								6								
	41	235						10	21	25	11	19	4	300	274	22,5
													8			
													5	500	474	18
													10			

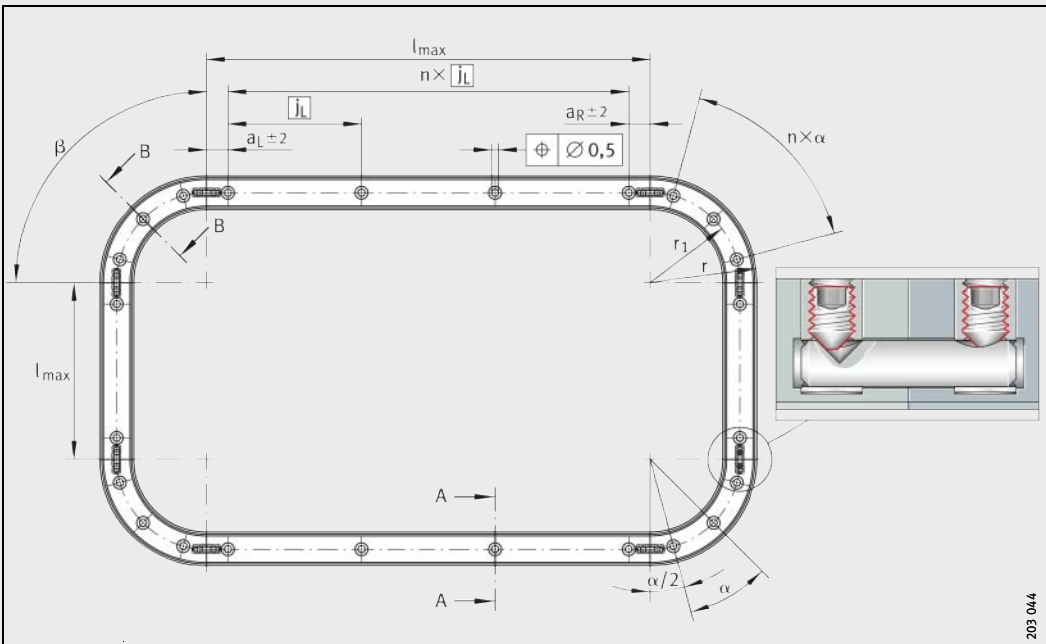

Closed oval track with four 90° arcs

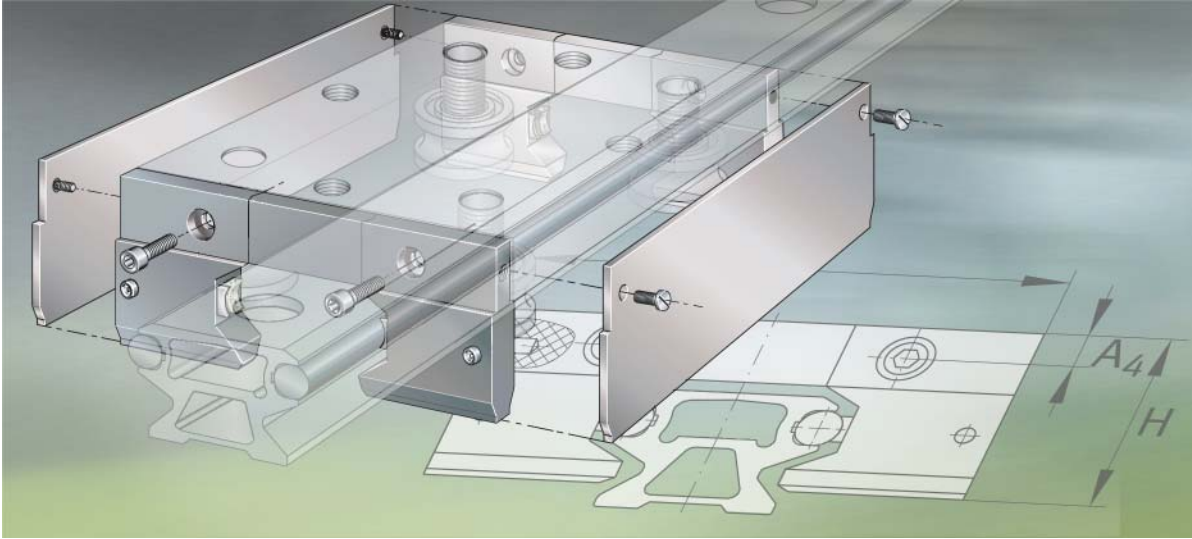

## Accessories

# Accessories

	Page
<b>Product overview</b>	
Accessories .....	106
<b>Features</b>	
Guideway connector for guideways .....	108
End plate.....	108
Lubrication and wiper units .....	109
Cap wipers .....	110
Side plate.....	111
Stops .....	111
End cover .....	111
Slot closing strip .....	111
Fasteners .....	112
<b>Dimension tables</b>	
Guideway connector for guideways LFS .....	114
End plate.....	115
Lubrication and wiper units .....	116
Cap wipers .....	118
Side plate.....	119
Stops .....	120
End cover .....	122
Slot closing strip .....	123



# Product overview Accessories

## Guideway connector for guideways

VBS

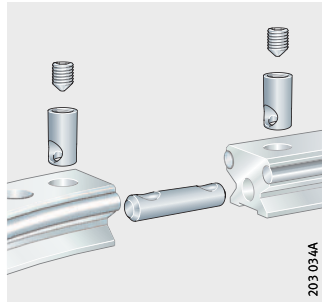

## End plate

ANS.LFS

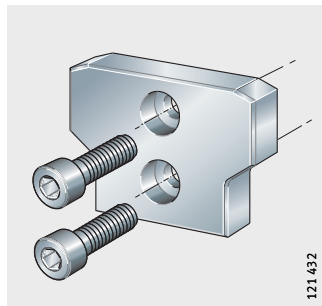

## Lubrication and wiper units

AB.W

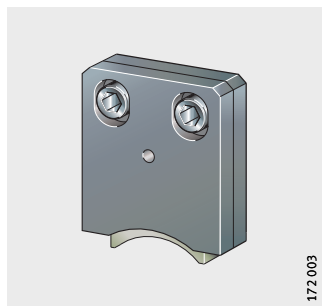

AB

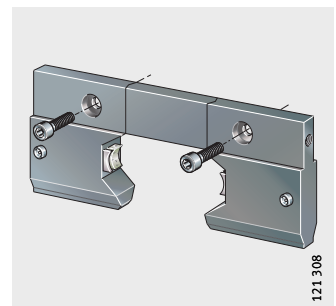

## Cap wipers

AB.LFR

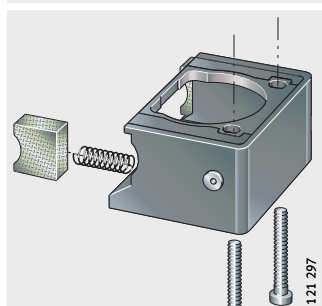

**Side plate**

ABAL

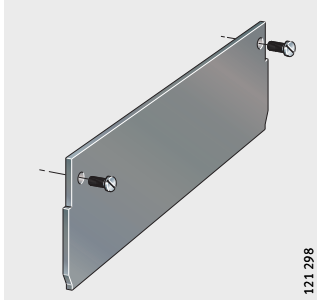

121 298

**Stops**

PAH

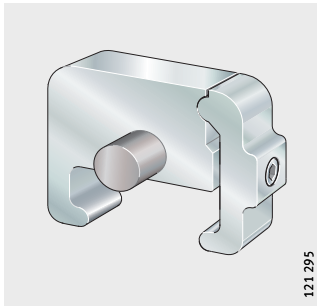

121 295

PASTP

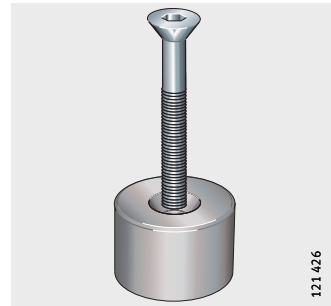

121 426

**End cover  
Slot closing strip**

KA.LFS

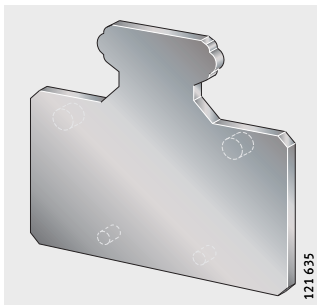

121 635

NAD

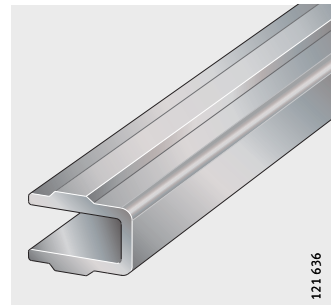

121 636

**Fasteners**

- Fixing screw
- T-nuts
- T-bolt
- T-strip
- Fixing bracket
- Fixing lug

MU, SHR, LEIS-M

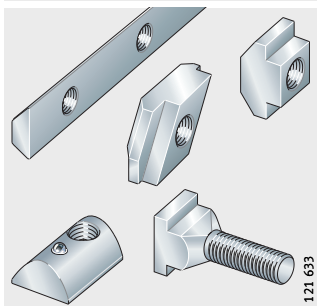

121 633

WKL, SPPR

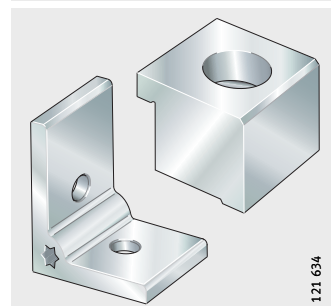

121 634



# Accessories

## Features

### Guideway connector for guideways

Guideway connectors VBS are accessories for curved and straight LFS guideways.

They comprise:

- pins
- bushes
- grub screws.

The guideway connectors are suitable for all LF guideways. Joined curved guideways are supplied as standard with the guideway connector. Joined straight guideways are available as an option with the guideway connector.

The VBS reduces running noise at the joint, ensures an increased operating life for the guidance system and improves the operational reliability.

### End plate

End plates ANS.LFS (also for use with hollow section guideways) are made from steel. They secure the rolled-in raceway shafts by means of form fit. In the case of solid section guideways, holes must be made in the end faces (by the customer) for screw mounting of the end plates.

The end plates prevent the shaft creep that can occur under unfavourable conditions on all guideways that comprise an aluminium support rail into which a steel shaft is rolled or pressed.



These can be supplied already fitted, but this must be indicated when ordering.

## Lubrication and wiper units

### Design AB.W

The lubrication and wiper unit AB.W comprises a plastic housing and is fixed to the adjacent construction. It contains a felt lubrication insert. This is supplied soaked with oil that has H1 approval and can be replenished with oil via a hole in the housing if necessary.

Lubrication and wiper units AB.W are supplied with fixing screws.

### Design AB

The lubrication and wiper unit AB comprises a plastic housing and is screw mounted to the end of the carriage LFL-SF or LFDL. It contains felt lubrication inserts on both sides. These are supplied soaked with oil that has H1 approval and can be replenished with oil via lubrication nipples if necessary. The lubrication and wiper units AB can be fixed to carriages using two screws.

If the lubrication and wiper unit AB is used together with a stop PAH or PASTP, the central section must be removed, see *Figure 1*.

- ① Central section, supplied loose
- ② Felt lubrication inserts
- ③ Fixing screws, supplied loose

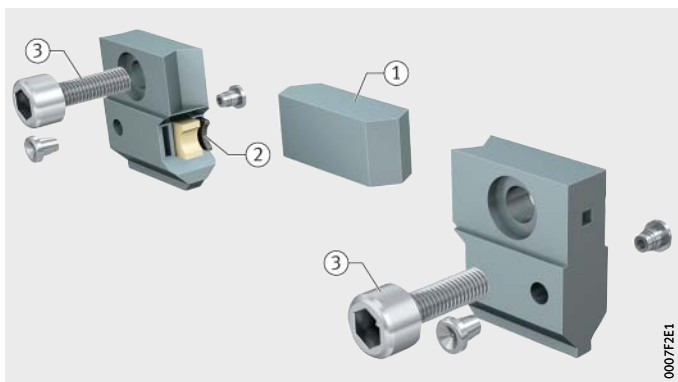

*Figure 1*  
Lubrication and wiper unit AB



# Accessories

## Cap wipers

The cap wipers comprise a plastic housing and are slid over the track roller from below. They contain felt lubrication inserts on both sides. These are supplied soaked with oil that has H1 approval and can be replenished with oil via lubrication nipples if necessary.

The cap wipers can be fixed using two screws to the screw mounting channels in the carriage LFCL and thus seal the track rollers from below at the screw head. When bolts LFZ and LFE are used in an application design, this gives a gap.

Cap wipers are supplied with fixing screws.

## Design AB.LFR

If two or more AB.LFR are used per side, the displacement resistance can be reduced by removing the felt insert on the inner side.

AB.LFR are suitable for mounting on the carriage LFCL42 as well as customer designs. For mounting on the carriage LFCL42, the upper cover must be replaced by the two covers supplied, *Figure 2*.

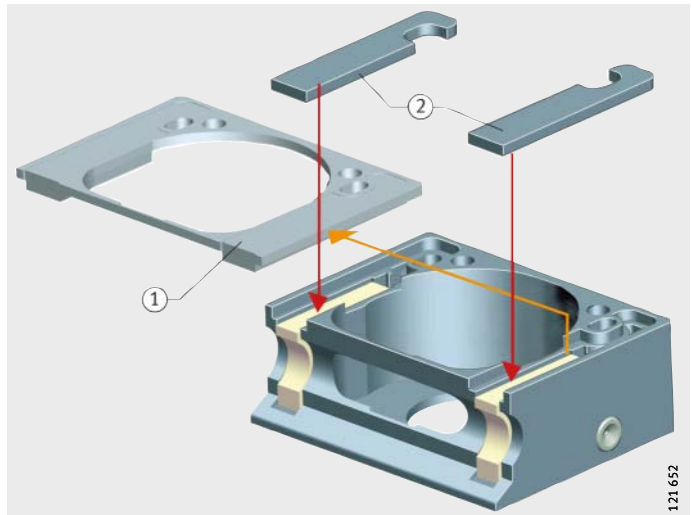

- ① For mounting on the customer design
- ② For mounting on LFCL42

*Figure 2*  
Mounting on carriage LFCL

## Design AB.LFR5302

An exception is the cap wiper AB.LFR5302. This comprises an end cover and a relubrication and wiper unit AB.W10 that can be screw mounted to either the right or left of the end cover. Its function and location correspond to those of the other sizes.



- Side plate** The side plate ABAL is made from plastic and can be screw mounted to the sides of carriages LFL...SF. The side plates are used to supplement the lubrication and wiper units AB. The carriage can be sealed on all sides, with the exception of the underside, by means of two side plates and two lubrication and wiper units.
- The side plate is supplied with fixing screws.
- It can only be mounted in conjunction with the lubrication and wiper unit AB.
- Stops**
- Design PAH** The stop PAH comprises anodised aluminium and a buffer made from shock-absorbent plastic. The stop can be placed at any position on guideways. It is then clamped in place by means of a screw.
- The stop is used as an end stop or restricts the travel of the carriage.
- The central section of lubrication and wiper units must be removed if the carriage is to run up against a stop PAH, see page 109.
- Design PASTP** The stop PASTP is made from plastic. It can be screw mounted in a threaded hole (to be made by the customer) in guideways. This hole can be drilled at any position on guideways LFS. The stop is used as an end stop or restricts the travel of the carriage.
- The central section of lubrication and wiper units must be removed if the carriage is to run up against a stop PASTP, see page 109.
- End cover** End covers KA are made from plastic. The end covers close off the end faces of the hollow sections in guideways LFS..-C and LFS..-M as well as in the hollow section carriage LFCL.
- Slot closing strip** Slot closing strips NAD are made from plastic. They close off the slots in the guideway LFS..-M. For information on NAD, see publication AL 1, Driven Linear Units.



# Accessories

## Fasteners

### Fixing brackets, fixing lugs

For location of LFS-M with the integral profiled aluminium support rail, fixing brackets and fixing lugs are available, *Figure 3, Figure 4, Figure 5* and table, page 113.

① WKL

*Figure 3*  
Fixing brackets

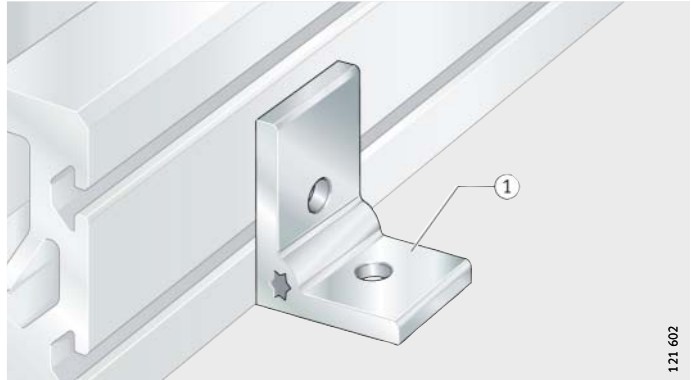

① SPPR

*Figure 4*  
Fixing lug

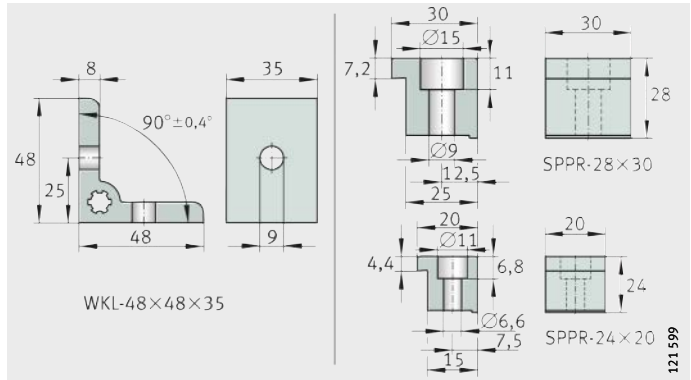
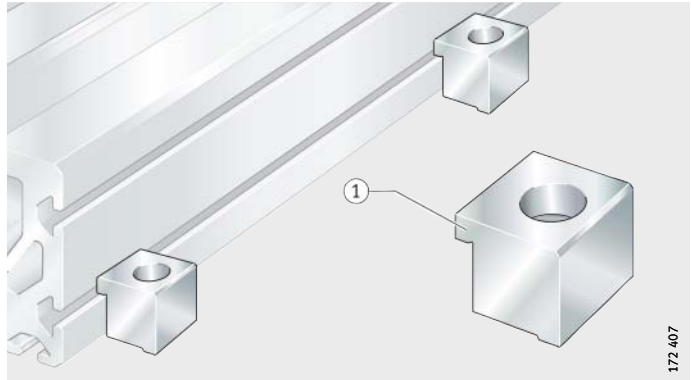

*Figure 5*  
Fixing brackets and fixing lugs

## T-strip, T-nuts, T-bolts

For integration in existing systems or for extension, T-strips, T-nuts and corresponding T-bolts are available, *Figure 6* and table.

- ① MU...-POS
- ② SHR-DIN787-M8×8×32
- ③ MU-M
- ④ MU-DIN508
- ⑤ LEIS-M, T-slot

*Figure 6*  
Fixing screws and T-nuts

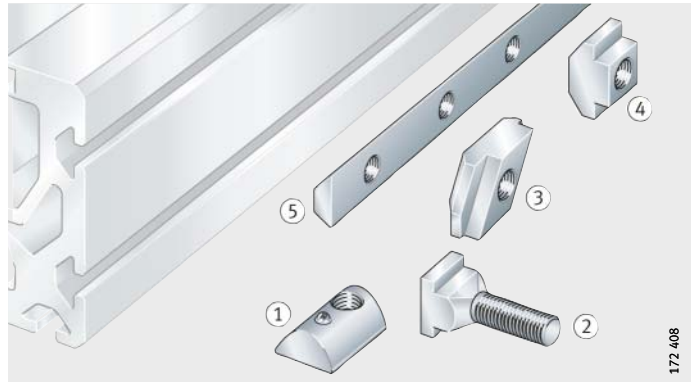

### Fasteners and designations

Fastener	Designation
Fixing bracket	WKL-48×48×35
For slot width 8 mm (LFS32-M, LFS52-M)	
Clamping lug	SPPR-28×30
T-nut	MU-DIN508-M4×8 MU-DIN508-M6×8
Rotatable T-nut	MU-M4×8-Rhombus MU-M6×8-Rhombus
Positionable T-nut	MU-M6×8-POS MU-M8×8-POS
T-bolt	SHR-DIN787-M8×8×32
T-strip (steel) Hole spacing 50 mm	LEIS-M6/8-T-Nut (state length) <sup>1)</sup> LEIS-M8/8-T-Nut (state length) <sup>1)</sup>
For slot width 5 mm (LFS25-M)	
Clamping lug	SPPR-24×20
T-nut	MU-DIN508-M4×5
Positionable T-nut	MU-M5×5-POS

<sup>1)</sup> Maximum single-piece length: 2 000 mm.



# Guideway connectors for guideways LFS

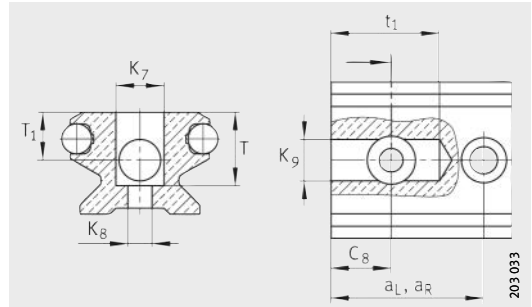

VBS

**Dimension table** - Dimensions in mm

Designation	Dimensions									For guideway
	T	T <sub>1</sub> ±0,1	t <sub>1</sub> +0,5	a <sub>L</sub> min.	a <sub>R</sub> min.	C <sub>8</sub> ±0,1	K <sub>7</sub> +0,2	K <sub>8</sub>	K <sub>9</sub> +0,5	
<b>VBS32</b>	16,5	10	25	30	30	15	12	6,5	9	LFS32, LFS32-E
<b>VBS32-R100</b>			17	22		9				LFS32, LFS32-E
<b>VBS42</b>	16,5	10	25	30	30	15	12	6,5	9	LFS42-C, LFS42-CE
<b>VBS52</b>	30	22	30	40	40	20	16	8	13	LFS52, LFS52-E, LFS52-EE, LFS52-C, LFS52-CE, LFS52-CEE
<b>VBS52-R150</b>			23	33		14				LFS52, LFS52-E, LFS52-EE, LFS52-C, LFS52-CE, LFS52-CEE

**Attention!**

If these are to be used with curved guideways LFSR or with straight guideways not included in the table, please contact us.

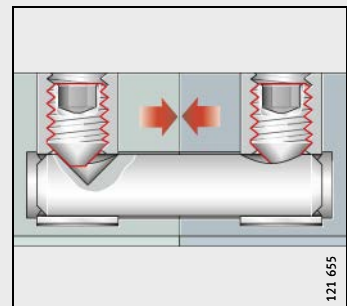

Guideway connector VBS

# End plate

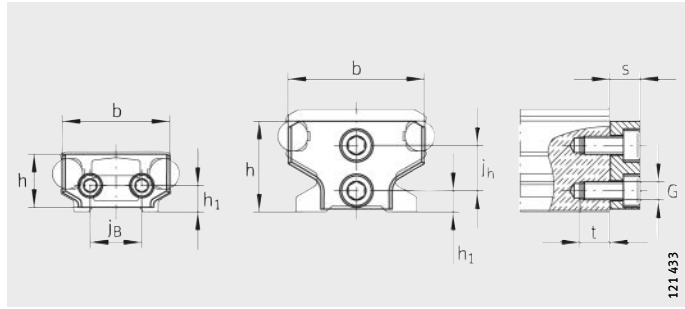

ANS.LFS, ANS.LFS42-C, ANS.LFS86-C, ANS.LFS..-NZZ

121 433

**Dimension table** · Dimensions in mm

Designation	Dimensions										For guideway
	b	j <sub>B</sub>	a	s	t	N <sub>3</sub> ∅	h	h <sub>1</sub>	j <sub>h</sub>	G	
<b>ANS.LFS20</b>	15,4	–	–	6	12	–	11	6,2	–	M5	LFS20
<b>ANS.LFS25</b>	20	–	–	5	7	–	14	4	7	M3	LFS25
<b>ANS.LFS32</b>	30	–	–	8	7	–	19	5	10	M4	LFS32
<b>ANS.LFS32-C</b>					15						12H13
<b>ANS.LFS32-F</b>	26	11	–	6	–	–	9	5	–	M4	LFS32-F
<b>ANS.LFS32-FH</b>	22	9	9		7					M3	LFS32-FH
<b>ANS.LFS32-N</b>	26	11	–	–	–	–	15	–	–	M4	LFS32-N
<b>ANS.LFS42-C</b>	35,5	17	–	8	7	–	18	8	–	M4	LFS42-C
<b>ANS.LFS52</b>	45	–	–	10	10	–	30	7	15	M6	LFS52
<b>ANS.LFS52-C</b>					20	19H13	30	–	∅11H13	LFS52-C	
<b>ANS.LFS52-F</b>	42	21	–	8	10	–	16	9	–	M5	LFS52-F
<b>ANS.LFS52-FH</b>	37	20	6,5								LFS52-FH
<b>ANS.LFS52-NZZ</b>	42	21	–					24			LFS52-NZZ
<b>ANS.LFS86-C</b>	80	54,1	–	9	20	–	30	17,5	–	M6	LFS86-C
<b>ANS.LFS120</b>	114	80	–	5	10	–	16	8	–	M6	LFS120

ANS cannot be mounted on:

LFS32-C: a<sub>L</sub>, a<sub>R</sub> < 28 mm

LFS52-C: a<sub>L</sub>, a<sub>R</sub> < 40 mm.

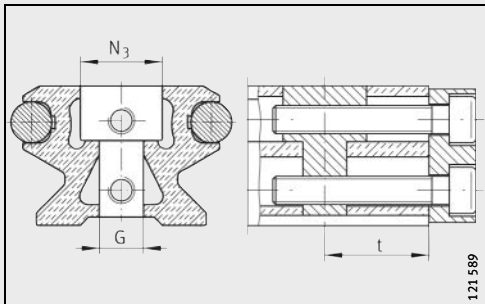

ANS.LFS32-C, ANS.LFS-52-C (hollow section)

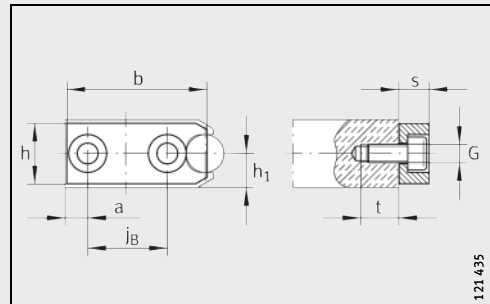

ANS.LFS..-F (-FH)



121 435

# Lubrication and wiper units

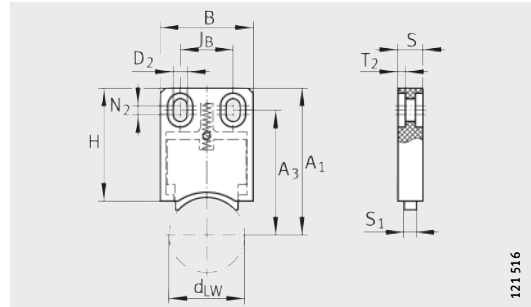

AB.W

121 516

**Dimension table** - Dimensions in mm

Designation	Mass m ≈ kg	Dimensions											For track roller
		d <sub>LW</sub>	B	S	H	J <sub>B</sub> ±0,1	D <sub>2</sub>	T <sub>2</sub>	S <sub>1</sub>	A <sub>1</sub>	N <sub>2</sub>	A <sub>3</sub>	
<b>AB.W10</b>	0,03	10	22,5	10	45	10	4,5	3	5	49	4	40,3	LFR5201, LFR5301, LFR5302
<b>AB.W12</b>	0,03	12	22,5	10	45	10	4,5	3	5	51	4	42,3	LFR5201-12
<b>AB.W16</b>	0,03	16	22,5	10	45	10	4,5	3	5	52	4	43,3	LFR5204-16
<b>AB.W20</b>	0,03	20	22,5	10	45	10	4,5	3	5	54	4	45,3	LFR5206-20
<b>AB.W25</b>	0,03	25	37	10	45	21	5,5	3	5	54	3,5	45,3	LFR5206-25
<b>AB.W30</b>	0,03	30	37	10	45	21	5,5	3	5	59	3,5	50,3	LFR5207-30
<b>AB.W40</b>	0,03	45	37	10	45	21	5,5	3	5	71	3,5	62,3	LFR5208-40
<b>AB.W50</b>	0,03	50	37	10	45	21	5,5	3	5	76	3,5	67,3	LFR5308-50

# Lubrication and wiper units

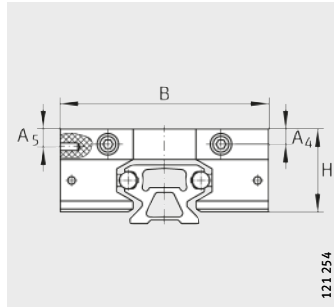

AB

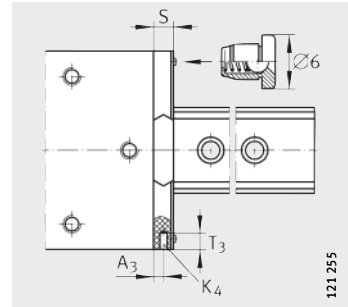

AB  
View rotated 90°

**Dimension table** - Dimensions in mm

Designation	Mass m ≈ kg	Dimensions								For carriage  For screws to DIN 7972
		B	T <sub>3</sub>	S	A <sub>3</sub>	H	A <sub>4</sub>	A <sub>5</sub>	K <sub>4</sub>	
<b>AB32</b>	0,03	80	6	11	5	32	7	7	ST2,9	LFL32-SF, LFL52-SF, LFL52-E-SF, LFDL32-SF, LFDL32-B <sup>1)</sup>
<b>AB52</b>	0,1	120	20	18	8,5	45,5	9,7	15	ST4,8	LFL32-SF, LFL52-SF, LFL52-E-SF, LFDL32-SF, LFDL32-B
<b>AB52-E</b>	0,13	135	20	18	8,5	55	12	20,6	ST4,8	LFL32-SF, LFL52-SF, LFL52-E-SF
<b>AB.LFLL32</b>	0,03	80	6	11	5	32	7	7	ST2,9	LFLL32-SF <sup>1)</sup>
<b>AB.LFLL52</b>	0,1	120	20	18	8,5	45,5	9,7	15	ST4,8	LFLL52-SF

<sup>1)</sup> Please contact us.



# Cap wipers

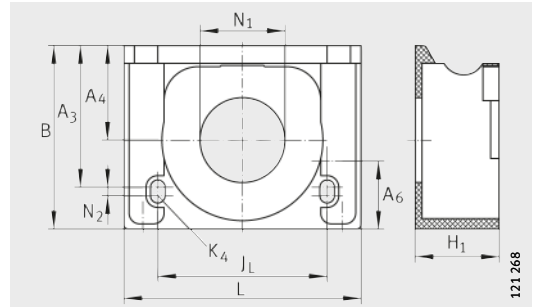

AB.LFR

**Dimension table** - Dimensions in mm

Designation	Mass m ≈ kg	Dimensions										For	
		B	A <sub>3</sub>	A <sub>4</sub>	N <sub>2</sub>	A <sub>6</sub>	L ±0,1	J <sub>L</sub>	H <sub>1</sub>	K <sub>4</sub>	N <sub>1</sub> +0,1	track roller	carriage
<b>AB.LFR50/8</b>	0,02	31,6	25,9	15,6	2	6,4	51	28,5	15	M3	15	LFR50/8	LFCL25
<b>AB.LFR5201</b>	0,02	43,3	33,4	22,3	2	16	56	40	21,3	M3	20	LFR5201	LFCL42
<b>AB.LFR5301</b>	0,03	50	38,7	26	2	10,4	76	46	25	M3	20	LFR5301	LFCL86
<b>AB.LFR5302<sup>1)</sup></b>	–	57	46	–	1,5	15,5	58	48	31	M3	–	LFR5302	–

<sup>1)</sup> Observe the note on page 110.



# Side plate

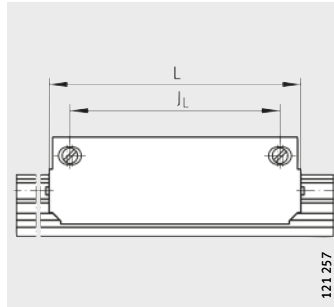

ABAL

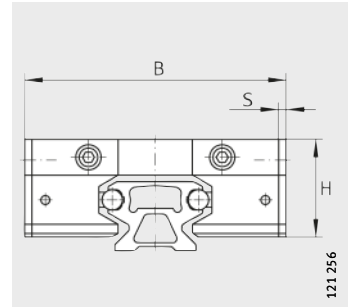

ABAL

**Dimension table** · Dimensions in mm

Designation	Mass m ≈ kg	Dimensions					For carriage
		B	S	L	J <sub>L</sub>	H	
<b>ABAL32</b>	0,03	86	3	112	100	32	LFL32-SF
<b>ABAL52</b>	0,04	130	5	136	117	49,5	LFL52-SF
<b>ABAL52-E</b>	0,05	145	5	186	167	55	LFL52-E-SF



# Stops

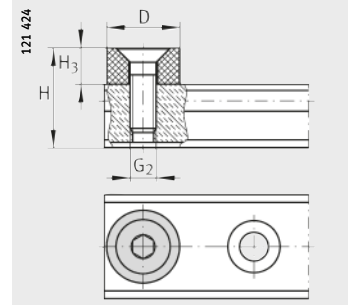

PASTP

**Dimension table** - Dimensions in mm

Designation	Mass m ≈ kg	Dimensions				For guideway
		D	H <sub>3</sub>	G <sub>2</sub>	H	
<b>PASTP20</b>	0,008	14	7	M5	22,2	LFS20
<b>PASTP25</b>	0,008	14	7	M5	25	LFS25
<b>PASTP32</b>	0,01	16	11	M6	31	LFS32
<b>PASTP42</b>	0,01	16	11	M6	31	LFS42-C
<b>PASTP52</b>	0,01	20	11	M8	45	LFS52
<b>PASTP86</b>	0,01	20	11	M8	45	LFS86-C

# Stops

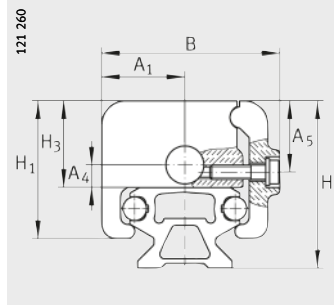

PAH

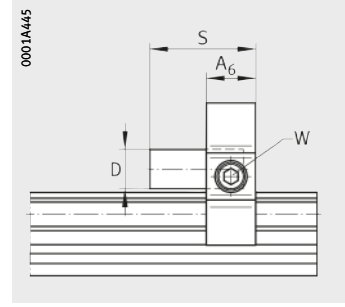

PAH  
View rotated 90°

**Dimension table** · Dimensions in mm

Designation	Mass m  ≈ kg	Dimensions										For guideway	
		B	A <sub>1</sub>	S	A <sub>6</sub>	D	H	H <sub>1</sub>	H <sub>3</sub>	A <sub>4</sub>	A <sub>5</sub>		Width across flats W
<b>PAH32</b>	0,05	46	21	30	15	10	39	32	19	7	14	5	LFS32-C
<b>PAH52</b>	0,17	75	35	43	20	16	70,5	58	36,5	9,5	30	6	LFS52-C (-NZZ)



# End cover

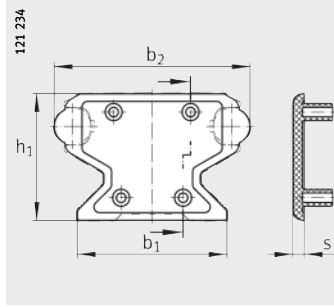

KA.LFS...-C

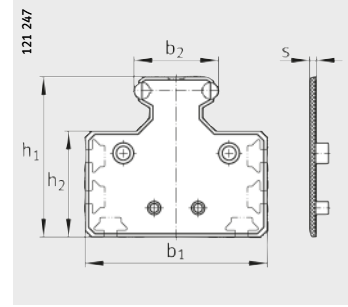

KA.LFS...-M

**Dimension table** - Dimensions in mm

Designation	Mass m ≈ kg	Dimensions					For guideway
		b <sub>2</sub>	b <sub>1</sub>	S	h <sub>1</sub>	h <sub>2</sub>	
KA.LFS25-M	0,01	24,4	55,4	3	45,4	30,9	LFS25-M
KA.LFS32-C	0,01	31,4	23,4	3	19,4	–	LFS32-C
KA.LFS32-M	0,012	31,4	75,4	3	59,9	46,4	LFS32-M
KA.LFS42-C	0,012	41,4	27,4	3	19,4	–	LFS42-C
KA.LFS52-C	0,013	51,6	39,5	3	33,4	–	LFS52-C
KA.LFS52-M	0,015	51,6	111,4	4	98	64,8	LFS52-M
KA.LFS86-C	0,015	85,6	70,4	3	33,4	–	LFS86-C

# Slot closing strip

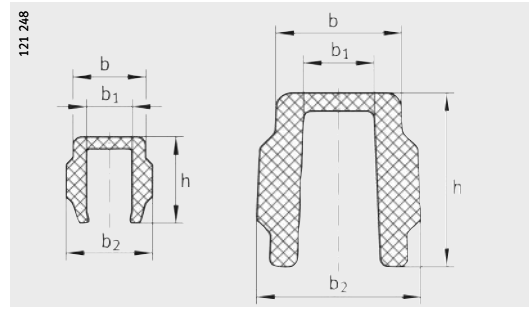

NAD

**Dimension table** · Dimensions in mm

Designation	Mass m ≈ kg	Dimensions				For guideway
		b	b <sub>1</sub>	b <sub>2</sub>	h	
<b>NAD5×5,7</b>	0,012	4,8	3	5,7	5,7	LFS25-M
<b>NAD8×11,5</b>	0,027	8,2	5,5	9,2	11,5	LFS32-M, LFS52-M

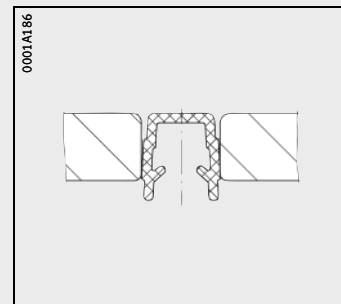

NAD5×5,7



# Addresses

- Germany** Schaeffler Technologies AG & Co. KG  
Linear Technology Division  
Berliner Straße 134  
66424 Homburg (Saar)  
Tel. +(49) 6841 701-0  
Fax +(49) 6841 701-2625  
info.linear@schaeffler.com
- Argentina** Schaeffler Argentina S.r.l.  
Av. Alvarez Jonte 1938  
C1416EXR Buenos Aires  
Tel. +(54) 11 40 16 15 00  
Fax +(54) 11 45 82 33 20  
info-ar@schaeffler.com
- Australia** Schaeffler Australia Pty Ltd.  
Level 1, Bldg. 8,  
Forest Central Business Park  
49 Frenchs Forest Road  
Frenchs Forest, NSW 2086  
Tel. +(61) 2 8977 1000  
Fax +(61) 2 9452 4242  
sales.au@schaeffler.com
- Austria** Schaeffler Austria GmbH  
Ferdinand-Pözl-Straße 2  
2560 Berndorf-St. Veit  
Tel. +(43) 2672 202-0  
Fax +(43) 2672 202-1003  
info.at@schaeffler.com
- Belarus** Schaeffler Technologies AG & Co. KG  
Repräsentanz Weißrußland  
Odoewskogo 117, office 317  
220015 Minsk  
Tel. +(375) 17 269 94 81  
Fax +(375) 17 269 94 82  
info.by@schaeffler.com
- Belgium** Schaeffler Belgium S.P.R.L./B.V.B.A.  
Avenue du Commerce, 38  
1420 Braine L'Alleud  
Tel. +(32) 2 3 89 13 89  
Fax +(32) 2 3 89 13 99  
info.be@schaeffler.com
- Bosnia-  
Herzegovina** Schaeffler Hrvatska d.o.o.  
Ogrizovićeva 28b  
10000 Zagreb  
Croatia  
Tel. +(385) 1 37 01 943  
Fax +(385) 1 37 64 473  
info.hr@schaeffler.com
- Brazil** Schaeffler Brasil Ltda.  
Av. Independência, 3500-A  
Bairro Eden  
18087-101 Sorocaba, SP  
Tel. +(55) 0800 11 10 29  
Fax +(55) 15 33 35 19 60  
sac.br@schaeffler.com
- Bulgaria** Schaeffler Bulgaria OOD  
Dondukov-Blvd. No 62  
Eing. A, 6. Etage, App. 10  
1504 Sofia  
Tel. +(359) 2 946 3900  
+(359) 2 943 4008  
Fax +(359) 2 943 4134  
info.bg@schaeffler.com

- Canada** Schaeffler Canada Inc.  
2871 Plymouth Drive  
Oakville, ON L6H 5S5  
Tel. +(1) 905 8 29 27 50  
+(1) 800 263 4397 (Toll Free)  
Fax +(1) 905 8 29 25 63  
info.ca@schaeffler.com
- China** Schaeffler Trading (Shanghai) Co., Ltd.  
No. 1 Antuo Road (west side of Anhong  
Road), Anting, Jiading District  
201804 Shanghai  
Tel. +(86) 21 3957 6500  
Fax +(86) 21 3959 3205  
info.cn-shanghai@schaeffler.com
- Croatia** Schaeffler Hrvatska d.o.o.  
Ogrizovićeve 28b  
10000 Zagreb  
Tel. +(385) 1 37 01 943  
Fax +(385) 1 37 64 473  
info.hr@schaeffler.com
- Czech Republic** Schaeffler CZ s.r.o.  
Průběžná 74a  
100 00 Praha 10  
Tel. +(420) 267 298 111  
Fax +(420) 267 298 110  
info.cz@schaeffler.com
- Denmark** Schaeffler Danmark ApS  
Jens Baggesens Vej 90P  
8200 Aarhus N  
Tel. +(45) 70 15 44 44  
Fax +(45) 70 15 22 02  
info.dk@schaeffler.com
- Estonia** Schaeffler Technologies  
Repräsentanz Baltikum  
Duntse iela 23a  
1005 Riga  
Latvia  
Tel. +(371) 7 06 37 95  
Fax +(371) 7 06 37 96  
info.lv@schaeffler.com
- Finland** Schaeffler Finland Oy  
Lautamiehentie 3  
02770 Espoo  
Tel. +(358) 207 36 6204  
Fax +(358) 207 36 6205  
info.fi@schaeffler.com
- France** Schaeffler France SAS  
93 route de Bitche, BP 30186  
67506 Haguenau Cedex  
Tel. +(33) 3 88 63 40 40  
Fax +(33) 3 88 63 40 41  
info.fr@schaeffler.com
- Great Britain** Schaeffler (UK) Ltd.  
Forge Lane, Minworth  
Sutton Coldfield B76 1AP  
Tel. +(44) 121 3 13 58 70  
Fax +(44) 121 3 13 00 80  
info.uk@schaeffler.com
- Hungary** Schaeffler Magyarország Ipari Kft.  
Rétköz utca 5.  
1118 Budapest  
Tel. +(36) 1 4 81 30 50  
Fax +(36) 1 4 81 30 53  
budapest@schaeffler.com
- Italy** Schaeffler Italia S.r.l.  
Via Dr. Georg Schaeffler, 7  
28015 Momo  
Tel. +(39) 0321 929 211  
Fax +(39) 0321 929 300  
info.it@schaeffler.com
- Japan** Schaeffler Japan Co., Ltd.  
New Stage Yokohama 1-1-32  
Shinurashima-cho  
222-0031 Yokohama  
Tel. +(81) 45 274 8211  
Fax +(81) 45 274 8221  
info-japan@schaeffler.com
- Korea** Schaeffler Korea Corporation  
14F, Kyobo life insurance Bldg.  
Seoul, 110-714  
Tel. +(82) 2 311 3440  
Fax +(82) 505-073-2042  
sangnam.lee@schaeffler.com



# Addresses

- Latvia** Schaeffler Technologies  
Repräsentanz Baltikum  
Duntes iela 23a  
1005 Riga  
Tel. +(371) 7 06 37 95  
Fax +(371) 7 06 37 96  
info.lv@schaeffler.com
- Lithuania** Schaeffler Technologies  
Repräsentanz Baltikum  
Duntes iela 23a  
1005 Riga  
Latvia  
Tel. +(371) 7 06 37 95  
Fax +(371) 7 06 37 96  
info.lv@schaeffler.com
- Mexico** INA Mexico, S.A. de C.V.  
Rodamientos FAG, S.A. de C.V.  
Henry Ford #141  
Col. Bondojito  
Deleg. Gustavo A. Madero  
07850 Mexico D.F.  
Tel. +(52) 55 5062 6085  
Fax +(52) 55 5739 5850  
distr.indl.mx@schaeffler.com
- Netherlands** Schaeffler Nederland B.V.  
Gildeweg 31  
3771 NB Barneveld  
Tel. +(31) 342 40 30 00  
Fax +(31) 342 40 32 80  
info.nl@schaeffler.com
- New Zealand** Schaeffler New Zealand  
(Unit R, Cain Commercial Centre)  
20 Cain Road  
1135 Penrose  
Tel. +(64) 9 583 1280  
+(64) 021 324 247  
(Call out fee applies)  
Fax +(64) 9 583 1288  
sales.nz@schaeffler.com
- Norway** Schaeffler Norge AS  
Grenseveien 107B  
0663 Oslo  
Tel. +(47) 23 24 93 30  
Fax +(47) 23 24 93 31  
info.no@schaeffler.com
- Poland** Schaeffler Polska Sp. z.o.o.  
Budynek E  
ul. Szyszkowa 35/37  
02-285 Warszawa  
Tel. +(48) 22 8 78 41 20  
Fax +(48) 22 8 78 41 22  
info.pl@schaeffler.com
- Portugal** INA Rolamentos Lda.  
Arrábida Lake Towers  
Rua Daciano Baptista Marques Torre C,  
181, 2<sup>o</sup> piso  
4400-617 Vila Nova de Gaia  
Tel. +(351) 22 5 32 08 00  
Fax +(351) 22 5 32 08 60  
info.pt@schaeffler.com
- Romania** S.C. Schaeffler Romania S.R.L.  
Aleea Schaeffler Nr. 3  
507055 Cristian/Brasov  
Tel. +(40) 268 505000  
Fax +(40) 268 505848  
info.ro@schaeffler.com
- Russia** Schaeffler Rußland GmbH  
Piskarevsky prospect, 2, build.3, letter A  
BC „Benua“, office 207  
195027 St. Petersburg  
Tel. +(7) 812 633 3644  
Fax +(7) 812 633 3645  
info.spb@schaeffler.ru  
  
Schaeffler Rußland  
Leningradsky Prospekt 47, Bau 3  
Business-Center Avion  
125167 Moscow  
Tel. +(7) 495 73776-60  
Fax +(7) 495 73776-61  
info.ru@schaeffler.com



- Serbia** Schaeffler Technologies  
Repräsentanz Serbien  
Branka Krsmanovica 12  
11118 Beograd  
Tel. +(381) 11 308 87 82  
Fax +(381) 11 308 87 75  
fagbgdyu@sezampro.yu
- Singapore** Schaeffler (Singapore) Pte. Ltd.  
151 Lorong Chuan, #06-01  
New Tech Park, Lobby A  
556741 Singapore  
Tel. +(65) 6540 8600  
Fax +(65) 6540 8668  
info.sg@schaeffler.com
- Slovak Republic** Schaeffler Slovensko, spol. s.r.o.  
Ullica Dr. G. Schaefflera 1  
02401 Kysucké Nové Mesto  
Tel. +(421) 41 4 20 59 11  
Fax +(421) 41 4 20 59 18  
info.sk@schaeffler.com
- Slovenia** Schaeffler Slovenija d.o.o.  
Glavni trg 17/b  
2000 Maribor  
Tel. +(386) 2 22 82 070  
Fax +(386) 2 22 82 075  
info.si@schaeffler.com
- South Africa** Schaeffler South Africa (Pty.) Ltd.  
1 End Street Ext. Corner Heidelberg Road  
2000 Johannesburg  
Tel. +(27) 11 225 3000  
Fax +(27) 11 334 1755  
info.co.za@schaeffler.com
- Spain** Schaeffler Iberia, s.l.u.  
C/ Foment, 2  
Polígono Ind. Pont Reixat  
08960 Sant Just Desvern  
Tel. +(34) 93 4 80 34 10  
Fax +(34) 93 3 72 92 50  
info.es@schaeffler.com
- Sweden** Schaeffler Sverige AB  
Charles gata 10  
195 61 Arlandastad  
Tel. +(46) 8 59 51 09 00  
Fax +(46) 8 59 51 09 60  
info.se@schaeffler.com
- Switzerland** Schaeffler Schweiz GmbH  
Badstraße 14  
8590 Romanshorn  
Tel. +(41) 71 4 66 66 66  
Fax +(41) 71 4 66 63 33  
info.ch@schaeffler.com
- Turkey** Schaeffler Rulmanlari Ticaret Limited  
Sirketi  
Aydin Sokak Dagli Apt. 4/4  
1. Levent  
34340 Istanbul  
Tel. +(90) 212 2 79 27 41  
+(90) 212 280 77 98  
Fax +(90) 212 281 66 45  
+(90) 212 280 94 45  
info.tr@schaeffler.com
- Ukraine** Schaeffler Technologies  
Representative Office Ukraine  
Jilyanskayastr. 75, 5-er Stock  
Business Center «Eurasia»  
01032 Kiev  
Tel. +(380) 44 520 13 80  
Fax +(380) 44 520 13 81  
info.ua@schaeffler.com
- USA** Schaeffler Group USA Inc.  
308 Springhill Farm Road  
Corporate Offices  
Fort Mill, SC 29715  
Tel. +(1) 803 548 8500  
Fax +(1) 803 548 8599  
info.us@schaeffler.com



**Schaeffler Technologies  
AG & Co. KG**

Linear Technology Division  
Berliner Straße 134  
66424 Homburg/Saar (Germany)  
Internet [www.ina.com](http://www.ina.com)  
E-mail [info.linear@schaeffler.com](mailto:info.linear@schaeffler.com)

In Germany:

Phone 0180 5003872

Fax 0180 5003873

From other countries:

Phone +49 6841 701-0

Fax +49 6841 701-2625

