

Rolling bearings

Plain bearings

Linear technology

FAG

Double Row Angular Contact Ball Bearings



SCHAEFFLER

X-LIFE – PROVEN TO BE BETTER

Longer rating and operating life – reliable

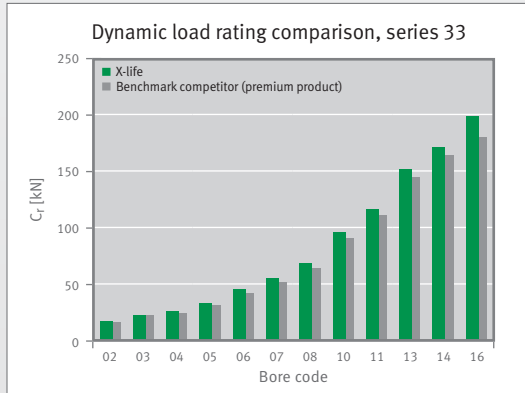

Product features

- Improved raceway surfaces
- Optimized internal construction
- Improved ball quality
- P6 manufacturing tolerances
- 30° contact angle
- Innovative HRS seal
- Optimized polyamide & steel cage
- Steel cage can be combined with gap or lip seals
- No filling slots required

Technical advantages

- 15% higher dynamic load rating C_r
- Longer operating life
- Longer rating life, particularly under axial loads and with large contact angles
- Reduced friction
- New robust, rigid steel cage
- Suitable for axial loads from both sides

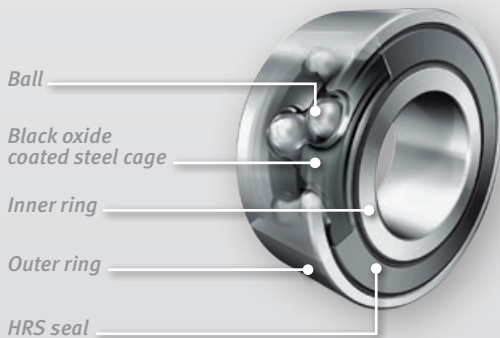

Customer benefits

- *20% longer rating and operating life*
- *Increased reliability*
- *Downsizing possible, higher power density*
- Low-noise applications
- Reduced energy consumption
- Reduced heat generation
- Higher speeds possible
- Extended maintenance intervals
- Reduced overall operating costs (TCO)

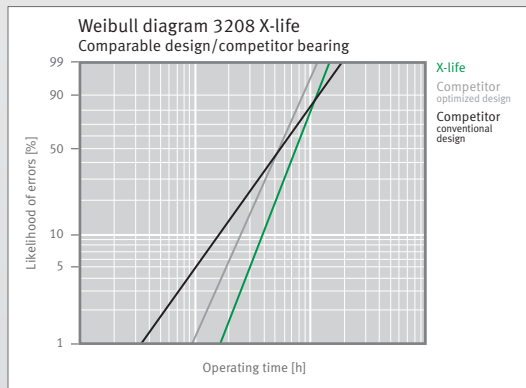

Applications

- Fluid pumps and compressors
- Industrial gearbox and automotive transmission applications
- Agricultural applications
- Conveying technology/elevators and packaging equipment
- Heavy motorcycles
- Machine tools and textile machinery



Types available

- 3202-BD to 3213-BD
- 3302-BD to 3316-BD

Schaeffler Technologies AG & Co. KG

Industriestrasse 1 – 3
91074 Herzogenaurach
Germany

Internet www.schaeffler.com/X-life
E-Mail X-life@schaeffler.com

Every care has been taken to ensure the correctness of the information contained in this publication but no liability can be accepted for any errors or omissions. We reserve the right to make technical changes.

© Schaeffler Technologies AG & Co. KG
Issued: 2015, February

This publication or parts thereof may not be reproduced without our permission.